

## Hot Iron Reference Data

This reference data has been extracted from various issues of Hot Iron. Putting it here, in a central location, means that it need not be repeated in each future issue of the newsletter. This makes it easier to maintain traffic to the subscriber mailing list.

**May 11, 2025 note:** The table of contents will in future be hyperlinked and page numbers properly identified, so you can jump right to the item of interest.

We will also be able to add other reference materials as we come across them, to expand and enhance the information contained here.

### **SAFETY NOTE, from Peter Thornton:**

Circuits shown in Hot Iron may use potentially lethal voltages. It is your responsibility to ensure your own – and anybody else's – safety if you build or use equipment that employs hazardous voltages, currents, power or any other injurious element. If in any doubt, you **MUST** get a competent person to check and approve the circuits, barriers and provisions to avoid any injury and electric shock. You **MUST** comply with your local Electrical Regulations and Safety Regulations.

We cannot accept any liability for any damage or injury to you or any Third Party from any article or description in Hot Iron. It is your responsibility to ensure the safety and safe use of anything you build. We are not responsible for any errors or omissions in Hot Iron, circuits are reproduced assuming the reader has a basic understanding of the safe use and implementation of electrical and electronic equipment and components.

If in doubt, don't do it: get professional, competent, qualified expert advice and help.

## Table of Contents

Basic AC Data, Relationships and Information.....	3
Components – Capacitance.....	4
Components – Class X and Y Capacitors.....	5
Components – Inductance.....	9
Chassis Holes for Valves/Tubes.....	9
The Unobtainium and Obsolescence Files: (substitutions; solid state and tube).....	10
Test Gear: ESR Tester.....	13
Electrolytics – Again!.....	14
Everything to know about Wire:	
Color Codes .....	14
AWG Table .....	16
Resistances per Foot .....	17
Current Ratings .....	18
Resistivities at Room Temperature .....	18
Thermal Conductivity at Room Temperature .....	18
Copper Wire Resistance Table .....	19
Wire Current Handling Capacity Values .....	19
Mains Wiring Current Ratings .....	21
Equipment Wires .....	21
Typical Current Ratings for Mains Wiring Inside Wall .....	21
Wire Sizes Used in USA Inside Wall .....	21
Equipment Wires in Europe .....	22
PCB Track Widths .....	22
Common Electrical Services and Loads .....	23
International Electrical Distribution Systems .....	26
AM/FM/VMARS Frequency Slots in Amateur HF Bands.....	27
Using a Power Transformer for Valve Audio Amp Outputs.....	28
Common Dielectric Insulating Properties Table.....	30
Power Tool Battery Terminal Identification .....	27

### Basic AC Data and Information

This information is for guidance only – you MUST comply with your local Electrical Safety Regulations! I have included information about AC power systems and conventions, as equipment can be bought from overseas nowadays and it's important to know how to connect it safely to our "home" supplies. Suffice to say, if there's ANY doubt - - GET PROFESSIONAL, COMPETENT HELP BEFORE YOU CONNECT TO ANY ELECTRICAL SUPPLY!

Basic AC Relationships:

**Crest Factor for various waves. [www.turneraudio.com.au](http://www.turneraudio.com.au)**

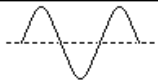
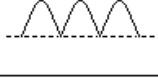
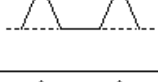
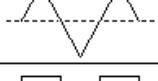
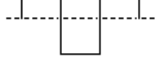
Wave type	Wave form	Mean magnitude (rectified)	Wave form Factor	RMS value	Crest Factor	Crest Factor
DC		1.00		1.00	1.00	0.0dB
Sine wave		$\frac{2}{\pi} \approx 0.6363$	$\frac{\pi}{2\sqrt{2}} \approx 1.1112$	$\frac{1}{\sqrt{2}} \approx 0.7071$	$\sqrt{2} \approx 1.4142$	3.01dB
Full-wave rectified sine wave		$\frac{2}{\pi} \approx 0.6363$	$\frac{\pi}{2\sqrt{2}} \approx 1.1112$	$\frac{1}{\sqrt{2}} \approx 0.7071$	$\sqrt{2} \approx 1.4142$	3.01dB
Half-wave rectified sine wave		$\frac{1}{\pi} \approx 0.3182$	$\frac{\pi}{2} \approx 1.5714$	$\frac{1}{2} = 0.50$	2.000	6.02dB
Triangle wave		$\frac{1.00}{2} = 0.50$	$\frac{2}{\sqrt{3}} \approx 1.1547$	$\frac{1}{\sqrt{3}} \approx 0.5773$	$\sqrt{3} \approx 1.7320$	4.77dB
Square wave		1.00	1.00	1.00	1.00	0.0dB

$\pi$  = greek letter pye, =  $22 / 7 = 3.142857134.....$  and is a mysterious and significant mathematical figure used in countless equations.  $\approx$  = symbol for "approximately equal to".

### COMPONENTS:

#### Back to Basics

I note from various places that some radio amateurs don't have a working grasp of the basics – the estimation of capacitance, inductance, and the like. Whilst you won't need this kind of information every day, it's still a basic requirement to building radio gear, especially if you're working on limited budgets or working from a modest "junque box".

The simple basics are more than adequate for most jobs, the basic approximations with their magnificent calculations built in fit the bill without straining the grey cells too much.

#### Capacitance:

$$C = E_o.E_r.A / D$$

where

$E_o = 8.85 \times 10^{-12}$  F/m (the Permittivity of free space);

Er = the Relative permittivity of the dielectric (i.e. what's between the capacitor plates)

For example, Air = 1; FR4 pcb board = 5; water = 80

A = area of the capacitor plates (in square metres)

D = the spacing between the plates (in metres)

OR... use <http://www.66pacific.com/calculators/capacitor-calculator.aspx>

Class X and Class Y capacitors... another aspect

I had some emails asking for clarification of "X" & "Y" class capacitor failure mechanisms; so from:

<https://www.allaboutcircuits.com/technical-articles/safety-capacitor-class-x-and-class-y-capacitors/>

below is an excerpt that will help clarify.

In simple terms, a class X capacitor will fail SHORT

CIRCUIT as it's meant to be connected line-to-line; the short will quickly blow the upstream fuses and clear the circuit.

A class Y capacitor will fail OPEN CIRCUIT, as it's meant to be connected

line-to-earth - which, if it failed short circuit, could make the earthed metal of a machine, tool, or equipment assume a high, possibly lethal, potential if the earth loop impedance is more than a few ohms. The passage below will explain better than I can:

Applications for Class-X and Class-Y Capacitors

Subclass X2 and Y2 are the most commonly used safety-certified capacitors. Depending upon your own application and requirements, they are probably the ones you'll want to use.

This is assumed because X2 and Y2 safety capacitors are used in common appliances that operate from ordinary household wall outlets.

To be clear, you should select your Class-X and Class-Y capacitors according to your design's purpose and requirements.

Whereas X2 and Y2 caps are appropriate for household applications, X1 and Y1 safety capacitors are used in industrial settings. As an example, a subclass X1 safety capacitor would be used for an industrial lighting ballast that is connected to a 3-phase line.

Of course, you could always use subclass X1 and Y1 in non-industrial applications, but you'll be spending more money and the larger sizes may prove inconvenient.

You might be asking, are X2 and Y2 safety capacitors interchangeable?

A Y2 capacitor can safely be used in place of an X2 capacitor, but an X2 capacitor should not be used in place of a Y2 capacitor. This is because, although an X2-type capacitor would work and filter noise sufficiently, it would not meet the line-to-ground safety standards.

Y2 safety capacitors are more robust, are able to withstand higher peak impulse voltages, and are designed to fail open circuit as opposed to failing short circuit.

There are also safety caps that combine aspects of X and Y types, such that they have met both X and Y safety requirements and standards. So for an X1/Y1 combination, this simply means that the capacitor can be used either as an X1 capacitor in a line-to-line application or as a Y1 capacitor in a line-to-ground application. Examples include the following:

- Vishay (PDF) offers their VY2 Class X1 (440 VAC) / Class Y2 (300 VAC) capacitor.
- Kemet (PDF) offers both X1/Y1 and X1/Y2 class combinations."

These capacitors are often seen in synchronous motor starters to give a phase shift voltage to a start winding. They can be very useful too as surge limiters in place of power resistors in HV power supplies, as described in Hot Iron #101, pp24; use class Y, to “fail open circuit” for safety.

Informative X-Y capacitor pages, courtesy of Vishay, follow on the next page:



VISHAY INTERTECHNOLOGY, INC.

[www.vishay.com](http://www.vishay.com)

Capacitors

Application Note

## AC Film Capacitors in Connection with the Mains

Because of the high energy availability and the severe environment of surge voltages and pulses, applications of capacitors in connection with the mains must be chosen carefully. Two kinds of connections and thus two kinds of applications can be distinguished. One is where the

capacitor is directly connected in parallel with the mains without any other impedance or circuit protection, and another where the capacitor is connected to the mains in series with another circuitry.

### CAPACITORS DIRECTLY CONNECTED IN PARALLEL WITH THE MAINS WITHOUT ANY OTHER IMPEDANCE OR CIRCUIT PROTECTION (ACROSS THE LINE OR X CLASS CAPACITORS)

To help reducing emission and increasing the immunity of radio interference, electromagnetic interference suppression film capacitors (EMI capacitors) are playing a major role in all kind of applications. These capacitors are put directly parallel over the mains at the input of the appliances.

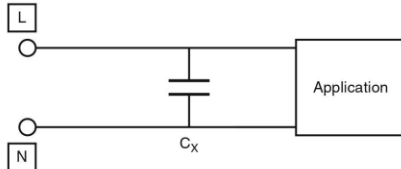

Several functions are combined in these small components: Excellent high frequency properties for short circuiting radio interference, being continuously stressed by the AC mains voltage and not at least having the ability to sustain transient voltages, caused by for example lightning strikes, switching, superimposed on this line.

For EMI capacitors it is a very difficult job to keep fulfilling the stringent requirements for safety and at the same time to

miniaturize for offering customers benefits in terms of costs, functionality and mounting possibilities.

Five main characteristics can be seen for EMI-capacitors:

- Excellent capacitive filter: Low inductance and equivalent series resistance are preferred
- Withstanding pulse loads: Uncontrolled mains switching must be sustained
- Continuous biased by the mains voltage: A powerful energy supply is always available
- Withstanding surge voltages: High energy surge voltages could destroy the capacitors
- Safe end of life behavior

It has been noted by several national authorities that safety is top priority for these components. Therefore international safety standards have been developed like IEC 60384-14 (world standard) and UL 60384-14 (US standard). National authorities prescribe that EMI capacitors to be connected directly in parallel with the mains must be proved to fulfill these standards. Approved products receive safety certificates and are allowed to have following safety marks:

COUNTRY	SAFETY STANDARD	APPROVAL MARK
U.S.A.	UL 60384-14	
Canada	CSA E384-14	
U.S.A. and Canada	Combination Mark (UL 60384-14 + CSA E384-14)	
China	CQC	
Europe	EN 60384-14 and IEC 60384-14	

Revision: 26-Jul-13

1

Document Number: 28153

For technical questions, contact: [rfi@vishay.com](mailto:rfi@vishay.com)

THIS DOCUMENT IS SUBJECT TO CHANGE WITHOUT NOTICE. THE PRODUCTS DESCRIBED HEREIN AND THIS DOCUMENT ARE SUBJECT TO SPECIFIC DISCLAIMERS, SET FORTH AT [www.vishay.com/doc?91000](http://www.vishay.com/doc?91000)

APPLICATION NOTE



# AC Film Capacitors in Connection with the Mains

Based on many years of experience Vishay has brought several EMI product series fulfilling these strong safety standards for across the line applications.

Depending on the customer's application needs following product series are recommended:

CLASS	X2	X1
<b>VOLTAGE</b>	$\leq 310 V_{AC}$	$\leq 480 V_{AC}$
Standard across the line applications, stability grade as per IEC 60384-14 <sup>(1)</sup>	MKP336-2 MKP338-2 MKP338-4 MKP339 F339MX2 F1778	MKP338-1 F339X1 330VAC
For continuous <sup>(2)</sup> across the line operation, higher stability grade than per IEC 60384-14 <sup>(1)</sup>	F1772	F339X1 480VAC

**Notes**

- <sup>(1)</sup> IEC 60384-14 endurance test conditions require  $\pm 10\%$  capacitance change after 1000 h testing
- <sup>(2)</sup> Continuous in the meaning of uninterrupted connected to the mains, 24 h/day during several years

### CAPACITORS CONNECTED TO THE MAINS IN SERIES WITH ANOTHER CIRCUITRY (SERIES IMPEDANCE APPLICATION)

In many appliances a low voltage supply is needed for simple low energy consuming functions like sensing, phase detection,... To reduce the voltage, reactive impedances are used like film capacitors.

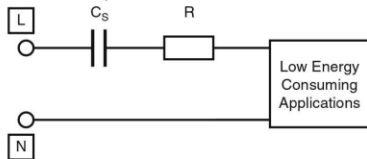

In this case the capacitors are connected in series with the application to the mains and now the functions to be fulfilled are:

- Stable voltage dropper: A stable capacitance must be guaranteed over the total lifetime of the application
- An adjusted tolerance: To guarantee a well defined current supply
- Continuous biased by almost the mains voltage: Internal ionization must be avoided

But what about withstanding surge voltages? And what about safety?

As these caps are connected through another circuitry, the equivalent impedance of this circuit can protect the capacitor. A film capacitor could be destroyed when a high

energy pulse is applied and the self healing properties are failing (self healing is the ability to recover after a breakdown). As general rule for standard capacitors, not approved according international standards for EMI capacitors, this can happen if surges occur higher than the guaranteed proof voltage. This is in general 1.6 times the rated DC voltage or 4.3 times the rated AC voltage. As it is generally accepted that surge voltage (1.2  $\mu$ s rise time/50  $\mu$ s duration) can occur at the entrance of appliances being 2.5 kV for installation category II and 4 kV for installation category III (IEC 60664-1), it must be verified by the customer that the impedance in series with the capacitor limits the over-voltage to these values. In general this will be the case because it can easily be calculated that equivalent impedances will be in the range of 220  $\Omega$  to a few k $\Omega$  depending on the low voltage application and by this the surge will be topped off to a few hundred volts maximum.

In all other conditions still an approved safety component must be used, but here the extra functions as stable capacitance and adjusted tolerance must be fulfilled as well. This can only be guaranteed by a different capacitor construction wherein two capacitor sections are internally connected in series.

Also for these series impedance applications Vishay can offer a wide range of products fulfilling customer's needs and requirements:

APPLICATION NOTE

CLASS	WITHOUT SAFETY APPROVALS <sup>(1)</sup>		WITH SAFETY APPROVALS	
	$\leq 275 V_{AC}$		$\leq 310 V_{AC}$	$\leq 480 V_{AC}$
Standard and continuous <sup>(2)</sup> in series with the mains operation	(3)		F1772	F339X1 480VAC

**Notes**

- <sup>(1)</sup> The applicant must guarantee that the maximum continuous mains voltage is lower than the rated AC voltage and that maximum temporary over-voltages (< 2 s) are lower than 1.6 rated DC voltage or 4.3 times AC rated voltage. Instructions can be found in the application notes and limiting conditions in the detail specifications.
- <sup>(2)</sup> Continuous in the meaning of uninterrupted connected to the mains, 24 h/day during several years
- <sup>(3)</sup> For the right choice of the component, contact [rfl@vishay.com](mailto:rfl@vishay.com)



## AC Film Capacitors in Connection with the Mains

### CAPACITORS DIRECTLY CONNECTED IN PARALLEL BETWEEN THE MAINS AND GROUND (LINE BYPASS OR Y CLASS CAPACITORS)

To help reducing common mode electromagnetic interference, capacitors are connected between mains and ground. For these applications only approved safety

components are allowed. Different safety classes and standards are defined in the same IEC 60384-14 and UL 60384-14 standards.

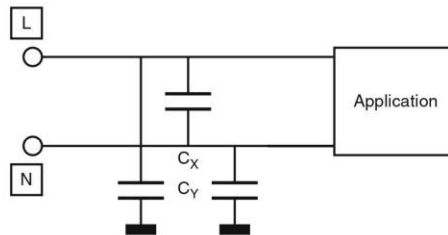

Vishay has following products in its film capacitor portfolio, adapted for the specific customers need:

CLASS	Y2
VOLTAGE	$\leq 305 V_{AC}$
Standard line bypass applications	F1710 MKP338-6
Line bypass application for continuous operation <sup>(1)</sup>	MKP338-6

**Note**

<sup>(1)</sup> Continuous in the meaning of uninterrupted connected to the mains, 24 h/day during several years

## Inductance

Of a single layer air cored solenoid =  $\text{Radius}^2 \times \text{Diameter}^2 / 9 \times \text{Radius} \times 10 \times \text{Length}$

With dimensions all in inches OR centimetres

OR... use

<http://www.66pacific.com/calculators/coil-inductance-calculator.aspx>

You can find the inductance of any toroid core here:

<http://www.66pacific.com/calculators/toroid-coil-winding-calculator.aspx>

OR

<https://www.daycounter.com/Calculators/Air-Core-Inductor-Calculator.phtml>

You can select the toroid material (iron powder for HF, ferrite for LF)

OR for air cored / non magnetic toroids  $\mu_r = 1$

<https://www.easycalculation.com/engineering/electrical/toroid-inductance-calculator.php>

## Valve / Tube chassis holes...

I measured the bases I have and these are the sizes. No doubt there are dimension drawings and preferred hole sizes on the web somewhere; I'm happy with those listed below most of the time - but I have a dandy half round file in my tool kit, just in case.

The one thing I miss in my home building stocks are the once-common Octal plugs, which were a rugged, robust, reliable and cheap means of making power supply and module interconnecting cables. I use DIN audio types nowadays, but they aren't a patch on the old Octal beasts.

Valve / Tube base Hole diameter Preferred metric and inch sizes

Valve / Tube base	Hole diameter	Preferred metric size
B7G	15mm (½")	15mm
B9A	19mm (¾")	19mm
International Octal	28.3mm or 1⅛" *	29mm**

\* Note: 5U4G (and many other) rectifiers fit "International Octal" sockets, but often, not all pins are implemented; the valve / tube is oriented correctly by the key on the octal base spigot.

\*\* If you can find one on your locale, that is. I found one in the UK at:

<https://www.toolstoday.co.uk/q-max-sheet-metal-punches-metric>

...but for our non-UK readers it might be a bit of a tussle - but then again, you'll likely have the Imperial sizes available? Octal and other valve bases were specified in "feet and inches", so those of you fortunate enough not to have to deal with Metrication have a flying start.

Octal socket holes are "usually" 1⅛" diameter; but beware, some ceramic holders may need different sizes, to accommodate clamp rings and mounts.

## The Substitutions Section:

The Unobtainium & Obsolete files...

A list of those solid state parts made from Unobtainium and Obsolete - please let me know your alternatives! Note: when Unobtainium and Obsolete parts are overheated, over-volted or overamped, the rare elements used inside the plastic / metal packaging react violently, emitting the "magic smoke" which renders any solid state device instantly useless. In a Yocto-second, no less.

Useful cross-reference web pages:

[https://english.electronic-pt.com/components-cross-reference?ref =](https://english.electronic-pt.com/components-cross-reference?ref=)  
<https://archive.org/details/TowersInternationalTransistorSelector>

For Solid State fans...

These are more or less equal equivalents, use in both directions i.e. BFY90 = 2N5178. Any more that have been proven in actual circuits, please let me know: the supplies of Unobtainium and Obsolete is getting harder and harder to find, any help is always welcome.

2N5179 BFY90 . watt VHF NPN

2N3866 BFY90 . watt VHF NPN

2N4427 BFR91 1 watt VHF / UHF NPN

ZTX300 BCY70 0.3 watt HF NPN

OA91 1N60/61 Ge signal diode, 50v, 50 mA

Alternatives to ZN414 = MK484, YS414, TA7642, UTC7642, LMF501T, LA1050.

For Valve / Tube fans...

[https://en.wikipedia.org/wiki/List\\_of\\_Mullard%E2%80%93Philips\\_vacuum\\_tubes](https://en.wikipedia.org/wiki/List_of_Mullard%E2%80%93Philips_vacuum_tubes)

(Well, you did ask...)

[http://www.angelfire.com/electronic/funwithtubes/tube\\_select\\_guide.html](http://www.angelfire.com/electronic/funwithtubes/tube_select_guide.html)

(THE 'Magnum Opus' of bottle lists)

<https://frank.pocnet.net/sheets5.html> (Is the broadest range of data sheets I've ever used, very helpful in finding usable alternatives)

Some not very obvious alternatives:

ECL 82 is an audio triode / pentode, much beloved in vintage radios, economy audio amps and the like.

However... if you have 12v. ac heater volts available (or higher) then the bottles following can be useful with a dropper resistor to tweak the heater volts down (and get long heater life too).

Don't forget that half wave rectified 12v. r.m.s. = 6v. r.m.s.; near enough for 6.3v. heaters; or strap two 6.3v. bottles in series if their heater currents are near equal, to run on 12v. AC - or a car battery.

ECL82 = LCL82 (10.7v heaters) = 11BM8 (10.7v heaters) or PCL82(16v) / UCL82(50v) / XCL 82(8.2v). There are dozens of equivalent or similar electrode structures but with different heaters.

For instance: PCL82 = 16A8 = 30PL12 = 16TP12 = 16TP6 = 16Φ3Π Different heater volts = 8B8 (8.3v ac)

Check the web page: [https://www.radiomuseum.org/dsp\\_searchtubes.cfm](https://www.radiomuseum.org/dsp_searchtubes.cfm) where you can search for many different tubes, characteristics and equivalents. For instance, web searching for an ECL84 equivalent - typically LCL84 - yields dozens of hits. If you want an ECL84, which are as rare as hen's teeth nowadays because Audiophools buy them at nosebleed prices, try the different heater volts equivalents and alter the heater supply appropriately.

Keep to mind that 5v or 6.3 v AC heater supplies, if doubled or trebled, will yield higher heater volts if you don't want to modify an existing or historically important piece of kit - but take great care not over volt filaments / heaters! A true RMS multimeter is handy for this job.

## HF & VHF Output Types:

6146B = 8298A = S2001; or nearly so,  
YL1370 = 6146 = 6146A = 6146W  
807 = VT-100 = QE06/50 = Г-807 = GL807 = RK-807 = A4051I = ZA3496 = CV124 = 5S1 = 4Y25N = VT199\_GPO  
= 5B/250A = CNU-807;  
nearly so = 10E/11441 ; 4Y25 ; ATS25 ; ATS25A ;  
ATS25N ; CV1364 ; CV1374 ; FU-7 ; HY61 ; QV05-25 ; RK39 ; VT60 ; VT60A

Audio valves; useful for low band RF:  
From an article by Robert H. Levi "My Favorite Tubes"  
by Robert H. Levi

Small Signal Tubes: 12AX7  
Substitutes: ECC83, 12AX7A, 12AX7WA, 7025, 5761, 6057, 6681, 7494, 7729, 7025#, ECC83#, 6L13, 12DF7,  
12DT7, 5751, 7025A, B339, B759, CV4004, E83CC, ECC803, M8137

The GE 5751 is a bargain basement musical giant! The Mullard CV4004 is still King of the Hill.

12AU7  
Substitutes: 12AU7A, ECC82, 5814, 5814A, 5814WA, 6189, 6680, CV4003, E82CC, ECC186, ECC802, ECC802S,  
M8136, 7025#, ECC83#, B749, 6067, 6670, 7730, B329, 5963, 7316, 7489 I discovered the 5814A from RCA is  
a bargain and the best sounding 12AU7 made in the USA!  
The Mullard CV4003 is still fairly cheap, plentiful, and magnificent.

12AT7  
Substitutes: 6201, 6679, ECC81, 12AT7WA, 12AT7WB, 6060, 6201, 6671, 6679, 7492, 7728, A2900, 8152,  
B309, B739, CV4024, E81CC, ECC801, ECC801S, M8162, QA2406, QB309  
As good as the GE and RCA are, the Mullard CV4024 is not pricey and totally glorious.

6DJ8  
Substitutes: ECC88, 6ES8#, 6ES8, ECC189, ECC189#, 6FW8, 6KN8, 6922, E88CC, CV2492  
The bargain priced PCC88, the 7 volt version of this tube, works nicely in the vast majority of 6 volt  
applications. I use them in a cocktail with their 6 volt brethren all the time for top results. You  
can still actually afford the Telefunken, Dutch Amperex, and Siemens versions of the PCC88!"

Rectifier Tubes:  
5AR4  
Substitutes: GZ34, 52KU, 53KU, 54KU, GZ30, GZ32, GZ33, GZ37, R52, U54, U77, 5R4GYS (from Philips) The  
Mullard GZ34 is King of the Hill. Buy it used, but checked, if necessary. The Philips 5R4GYS is a recent find by  
Upscale Audio in Upland. A killer tube, but huge and requires  
lots of space (bigger than a KT88.)

Other Dual Triode Tubes:  
6SN7  
Substitutions: 6SN7A, 6SN7GT, 6SN7GTA, 6SN7GTB, 6SN7W, 6SN7WGT, 65W7, 5692, B65, ECC33, 6SN7L,  
13D2, B65, 6SN7GTY, 6SN7WGTA  
The vintage GE and RCA are very fine if hand selected. The Electro Harmonix is very good, too.

6SL7

Substitutes: 5691, 6SL7W, 6SL7WGT, 6113, ECC35, 6SL7GT, 6SL7L

Same comment as 6SN7 type.

Output Tubes:

EL84

Substitutes: 6BQ5, 6P15, 6267, 7189, 7189A, 7320, E84L, EL84L, N709, Z729, 6BQ5WA, EL84M I have had little use for these. Am told the NOS Mullard prices are strong, but worth it.

EL34

Substitutes: 6CA7, 7D11, 12E13, KT77

Lots to choose from. Usually your manufacturer tuned the gear to a certain brand of these. Be mindful of that before you spend tons of money on vintage NOS versions that end up not sounding as good.

6550

Substitutes: 7D11, 12E13, 6550A, 7027A#, KT88, KT90 Type 2 or 3, KT99, KT100, KT120/KT150 (only if sufficient bias is present) Unless forbidden by your manufacturer, I would try some of the high powered goodies on the market to boost performance. The EH KT90 or the new KT120 may be astounding in your amp. At least try KT88s!

6L6

Substitutes: KT66, 5881, 6L6S, 6L6G, 6L6GA, 6L6GAY, 6L6WA, 6L6WGA, 6L6WGB, 6L6WGC, 6L6WGT, 6L6GB, 6L6GC, 6L6GT, 6L6GX, 6L6Y, 1622, 5932, 7581, 7581A, WT6, EL37 Same comment as EL34 type.

KT88

Substitutes: 6550, 6550A, KT90 Type 2 or 3, KT99, KKT100, KT120/KT150 (only if sufficient bias present) Though your manufacturer may have settled on a certain brand of these, the hunt for cool NOS types may be sonically worthwhile, or try switching to EH KT90s or bigger for more impact. I would!

Test Gear / Maintenance

Simplest ESR tester for electrolytics

Equivalent Series Resistance is a measure of the current capability and life left in an capacitor, oiled paper, ceramic, or electrolytic and is a "go-to" wonder for the service technician. You can buy hand-held gizmos to do this... but we prefer to make our own from junk!

<https://www.homemade-circuits.com/esr-meter-circuit/>

I don't think I've seen a simpler method? Much to recommend it for high ripple rated power supply electrolytics removed from circuit for testing, but watch back-biasing electrolytics. I think I'd drop the transformer secondary to 3 volts or so to reduce the back stress on the electrolytic.

OR:

<https://ludens.cl/Electron/esr/esr.html> which is an in-circuit tester using only a few hundred mV of drive applied to the capacitor. This is almost THE standard for bench ESR testing; most of the small gadget gizmos use this approach.

**Electrolytics – again...**

Electrolytic capacitors work miracles; let there be no doubt about that. To squeeze all those  $\mu\text{F}$ 's into such a small size, delivering current millions of times yet still remaining leakage free (more or less) is a technological marvel. But... as we have seen previously, they are a common cause of breakdowns, trouble and general bad behaviour. One feature I have observed over the years is value and voltage rating "creep". This occurs typically when an electrolytic is run below its nominal rated voltage; i.e. a 450v rated capacitor running on rectified 230v AC rms, typically  $\sim 310\text{v}$  DC.

What happens is the capacitance creeps UP; and the voltage rating FALLS to match the applied voltage. Not all electrolytics do this; I've seen it in signal coupling capacitors, and in the DC bus reservoir capacitors in 10kW motor inverters running at 20kHz. There seems to be no rhyme nor reason why one capacitor will show this "creep", yet its neighbour, of apparently identical parentage, remains exactly as marked on the tin.

The effect (I guess?) is caused by the insulating layer becoming thinner as the lower than rated applied voltage doesn't maintain the electric field in the electrolyte required to create the insulation; the layer becomes thinner to match the voltage applied. Since  $C = \epsilon \cdot A / D$ , and "D" is getting smaller, then C rises proportionately. The moral is this: if you put a bit of kit on another supply, higher in voltage than the one you usually run it on, then beware: odd results after a day or two might point to an electrolytic going off to the land of its fathers, after suffering "creep" and the voltage rating has fallen, the now higher voltage is breaking it down.

## Everything About Wire!

Wire Colour Code Information...

As used in Test Gear Maintenance at a factory I worked at:

Green (or green & yellow stripe) - Earths, Chassis connection

Blue A.C. power lines (N, single  $\Phi$ , inside machinery)

Brown A.C. power lines (L, single  $\Phi$ , inside machinery)

Note: 3 $\Phi$  supplies external to machinery or distribution systems may use some of these colours; check, check and check again what the wiring is!

NEVER, NEVER, assume a blue wire is a neutral; you may have an old 3 $\Phi$  installation which ran colours as follows:

Red Phase 1

Yellow Phase 2

Blue Phase 3

Black Neutral

Valve Electrode wiring:

Gray heaters or filaments

Red DC power supply positives (numbered sleeves indicating voltage)

Black returns, commons, NOT grounded

Orange screen grids

Yellow cathodes

Pink control grids

White anodes

Violet AC / DC control signals (AGC, etc.)

From Kevin, VK3DAP / ZL2DAP, seen on a web page recently, is another wiring code - last seen in a Savage 5kW audio amplifier driving a vibration table for semiconductor testing:

Valve Electrodes:

Anode Blue

Cathode Yellow

Control grid Green  
Screen Grid Orange  
Suppressor Grey

DC Supplies:

Chassis / Ground Black  
Positive to Chassis Red  
Negative to Chassis Violet

Miscellaneous Wiring (control signals & the like):

White or mauve

AC Supplies (modern UK & European):

Active or Phase Brown  
Neutral Blue  
Earth Green/Yellow stripe

U.S.A. Common Cable colour Codes (AC only!)

American electrical contractors and electricians are required to follow the National Electrical Code ("NEC") with regard to wiring colours. NEC imposes the following electrical wiring colour standards:

- Ground wires: green, green with a yellow stripe, or bare copper
- Neutral wires: white or grey

In theory, wiring conducting live current in the U.S. is permitted to be any other colour, although in practice, electrical contractors and electricians follow these local conventions:

- Single phase live wires: black (or red for a second "hot" wire)
- 3-phase live wires: black, red and blue for 208 VAC; brown, yellow, purple for 480 VAC

Most countries in Europe, including the U.K., now follow the colour conventions established by the International Electrotechnical Commission ("IEC"). These colour conventions are as follows:

- Earth wires (called ground wires in the U.S. and Canada): green with a yellow stripe
- Neutral wires: blue
- Single phase live wires: brown
- 3-phase live wires: brown, black and grey

Electrical wiring in Canada is governed by the Canadian Electric Code ("CEC"). The following wiring colour requirements apply in Canada:

- Ground wires: green, or green with a yellow stripe
- Neutral wires: white
- Single phase live wires: black (or red for a second live wire)
- 3-phase live wires: red, black and blue

It's important to remember that the above colour information applies only to AC circuits.

AWG Table

- 1 AWG is 289.3 thousandths of an inch
- 2 AWG is 257.6 thousandths of an inch
- 5 AWG is 181.9 thousandths of an inch
- 10 AWG is 101.9 thousandths of an inch

20 AWG is 32.0 thousandths of an inch  
30 AWG is 10.0 thousandths of an inch  
40 AWG is 3.1 thousandths of an inch

The table in ARRL handbook warns that the figures are approximate and may vary dependent on the manufacturing tolerances. If you don't have a chart handy, you don't really need a formula.

There are several handy tricks:

Solid wire diameters increases/decreases by a factor of

2 every 6 gauges,

" " " " 3 every 10 gauges,

" " " " 4 every 12 gauges,

" " " " 5 every 14 gauges,

" " " " 10 every 20 gauges,

" " " " 100 every 40 gauges,

With these, you can get around a lot of different AWGs and they cross check against one another.

Start with solid 50 AWG having a 1 mil diameter.

So, 30 AWG should have a diameter of ~ 10 mils.

36 AWG should have a diameter of ~ 5 mils. Dead on.

24 AWG should have a diameter of ~ 20 mils. Actually ~ 20.1

16 AWG should have a diameter of ~ 50 mils. Actually ~ 50.8

10 AWG should have a diameter of ~ 100 mils. Actually ~ 101.9

If you are more interested in current carrying ability than physical size, then also remember that a change of 3 AWG numbers equals a doubling or halving of the circular mils (the cross sectional area). Thus, if 10 AWG is safe for 30 amps, then 13 AWG (hard to find) is ok for 15 amps and 16 AWG is good for 7.5 amps.

The wire gauge is a logarithmic scale based on the cross sectional area of the wire. Each 3-gauge step in size corresponds to a doubling or halving of the cross sectional area. For example, going from 20 gauge to 17 gauge doubles the cross sectional area (which, by the way, halves the DC resistance).

So, one simple result of this is that if you take two strands the same gauge, it's the equivalent of a single wire that's 3 gauges lower. So two 20 gauge strands is equivalent to 1 17 gauge.

Wire Gauge Resistance per foot

4 .000292

6 .000465

8 .000739

10 .00118

12 .00187

14 .00297

16 .00473

18 .00751

20 .0119

22 .0190

24 .0302

26 .0480

28 .0764

### Current ratings

Most current ratings for wires (except magnet wires) are based on permissible voltage drop, not temperature rise. For example, 0.5 mm<sup>2</sup> wire is rated at 3A in some applications but will carry over 8 A in free air without overheating. You will find tables of permitted maximum current in national electrical codes, but these are based on voltage drop. Here is a current and AWG table.

AWG	dia mils	circ mils	open air Amp	cable Amp	ft/lb bare	ohms/1000'
10	101.9	10380	55	33	31.82	1.018
12	80.8	6530	41	23	50.59	1.619
14	64.1	4107	32	17	80.44	2.575

Mils are .001". "open air A" is a continuous rating for a single conductor with insulation in open air. "cable amp" is for in multiple conductor cables. Disregard the amperage ratings for household use. To calculate voltage drop, plug in the values:

$$V = IR/1000$$

Where I is the amperage, R is from the ohms/1000' column above, and D is the total distance the current travels (don't forget to add the length of the neutral and live together - ie: usually double cable length). Design rules call for a maximum voltage drop of 6% (7V on 120V circuit).

### Resistivities at room temp:

Element Electrical resistivity (micro-ohm-cm)

Aluminium 2.655

Copper 1.678

Gold 2.24

Silver 1.586

Platinum 10.5

This clearly puts silver as the number one conductor and gold has higher resistance than silver or copper. It's desirable in connectors because it does not oxidise so remains clean at the surface. It also has the capability to adhere to itself (touch pure gold to pure gold and it sticks) which makes for very reliable connections.

### Thermal conductivity at room temperature

W/cm<sup>2</sup>/°C

silver 4.08

copper 3.94

gold 2.96

platinum 0.69

diamond 0.24

44

bismuth 0.084

iodine 43.5E-4

This explains why diamonds are being used for high power solid state substrates now - that's manmade diamond. Natural diamonds contain flaws in the lattice that phonons (heat conductors) get scattered and substantially reduce the ability to transport the heat.

***Copper wire resistance table***

AWG	Feet/Ohm	Ohms/100ft	Ampacity	(mm <sup>2</sup> )	Meters/Ohm	Ohms/100M
10	490.2	.204	30	2.588	149.5	.669
12	308.7	.324	20	2.053	94.1	1.06
14	193.8	.516	15	1.628	59.1	1.69
16	122.3	.818	10	1.291	37.3	2.68
18	76.8	1.30	5	1.024	23.4	4.27
20	48.1	2.08	3.3	0.812	14.7	6.82
22	30.3	3.30	2.1	0.644	9.24	10.8
24	19.1	5.24	1.3	0.511	5.82	17.2
26	12.0	8.32	0.8	0.405	3.66	27.3
28	7.55	13.2	0.5	0.321	2.30	43.4

These Ohms / Distance figures are for a round trip circuit. Specifications are for copper wire at 77 degrees Fahrenheit or 25 degrees Celsius.

***Wire current handling capacity values***

mm <sup>2</sup>	R/m-ohm/m	I/A
6	3.0	55
10	1.8	76
16	1.1	105
25	0.73	140
35	0.52	173
50	0.38	205
70	0.27	265

## Mains wiring current ratings

In mains wiring there are two considerations, voltage drop and heat build up. The smaller the wire is, the higher the resistance is. When the resistance is higher, the wire heats up more, and there is more voltage drop in the wiring. The former is why you need higher-temperature insulation and/or bigger wires for use in conduit; the latter is why you should use larger wire for long runs.

Neither effect is very significant over very short distances. There are some very specific exceptions, where use of smaller wire is allowed. The obvious one is the line cord on most lamps. Don't try this unless you're certain that your use fits one of those exceptions; you can't go wrong using larger wire. This is a table apparently from BS6500, reproduced in the IEE Wiring Regs which describes the maximum fuse sizes for different conductor sizes:

Cross-section	Overload current
CSA / area	rating
0.5mm <sup>2</sup>	3A
0.75mm <sup>2</sup>	6A
1mm <sup>2</sup>	10A
1.25mm <sup>2</sup>	13A
1.5mm <sup>2</sup>	16A

### Equipment wires

mm <sup>2</sup>	A
0.5	3
0.75	6
1.0	10
1.5	16
2.5	25

### Typical current ratings for mains wiring Inside wall

mm <sup>2</sup>	Amps
1.5	10
2.5	16

### Wire sizes used in USA inside wall

For a 20 amp circuit, use 12 gauge wire. For a 15 amp circuit, you can use 14 gauge wire (in most locales). For a long run, though, you should use the next larger size wire, to avoid voltage drops.

Here's a quick table for normal situations. Go up a size for more than 100 foot runs, when the cable is in conduit, or ganged with other wires in a place where they can't dissipate heat easily:

Gauge	Amps
14	15
12	20
10	30
8	40
6	65

### *Equipment wires in Europe*

3 core equipment mains cable

Current	3A	6A	10A	13A	16A
Conductor size (mm)	16*0.2	24*0.2	32*0.2	40*0.2	48*0.2
Copper area (mm <sup>2</sup> )	0.5	0.75	1.0	1.25	1.5

Cable ratings for 3A, 6A and 13A are based on BS6500 1995 specifications and are for stranded thick PVC insulated cables.

Insulated hook-up wire in circuits (DEF61-12)

Max. current	1.4A	3A	6A
Max. working voltage (V)	1000	1000	1000
PVC sheath thickness (mm)	0.3	0.3	0.45
Conductor size (mm)	7*0.2	16*0.2	24*0.2
Conductor area (mm <sup>2</sup> )	0.22	0.5	0.75
Overall diameter (mm)	1.2	1.6	2.05

### **PCB track widths**

For a 10 degree C temp rise, minimum track widths on 1 oz. copper are:

Current	width in inches
0.5A	0.008"
0.75A	0.012"
1.25A	0.020"
2.5A	0.050"
4.0A	0.100"
7.0A	0.200"
10.0A	0.325"

Electrical Supplies - Courtesy LEGRAND equipment

### Common Electrical Services & Loads

In the following drawings, the coil symbols represent the secondary winding of a utility service transformer or other step down transformer. Electrical code regulations in most jurisdictions require that the neutral conductor be bonded (connected) to the earth safety ground at the electrical service entrance.

### Single Phase Three Wire

#### Single Phase Three Wire

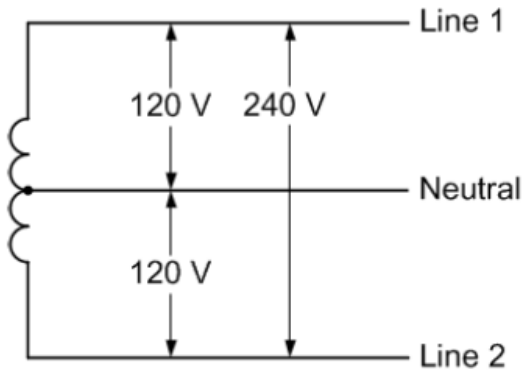

Also known as an Edison system, split-phase or centre-tapped neutral. This is the most common residential service in North America. Line 1 to neutral and Line 2 to neutral are used to power 120 volt lighting and plug loads. Line 1 to Line 2 is used to power 240 volt single phase loads such as a water heater, electric range, or air conditioner.

### Three Phase Four Wire Wye

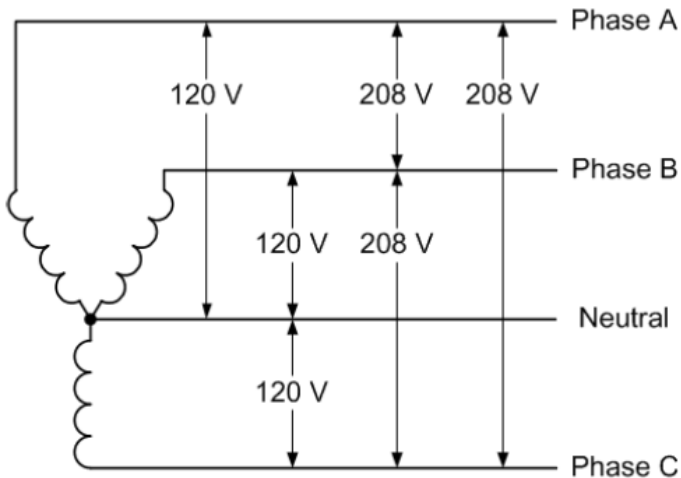

The most common commercial building electric service in North America is 120/208 volt wye, which is used to power 120 volt plug loads, lighting, and smaller HVAC systems. In larger facilities the voltage is 277/480 volt and used to power single phase 277 volt lighting and larger HVAC loads.

In western Canada 347/600V is common.

### Three Phase Three Wire Delta

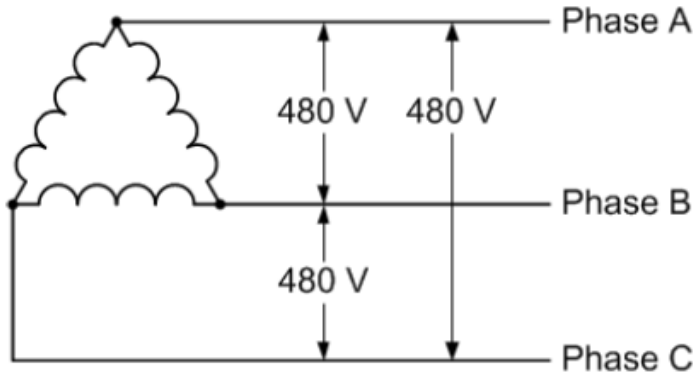

Used primarily in industrial facilities to provide power for three-phase motor loads, and in utility power distribution applications. Nominal service voltages of 240, 400, 480, 600, and higher are typical.

### Uncommon Electrical Services

#### Three Phase Four Wire Delta

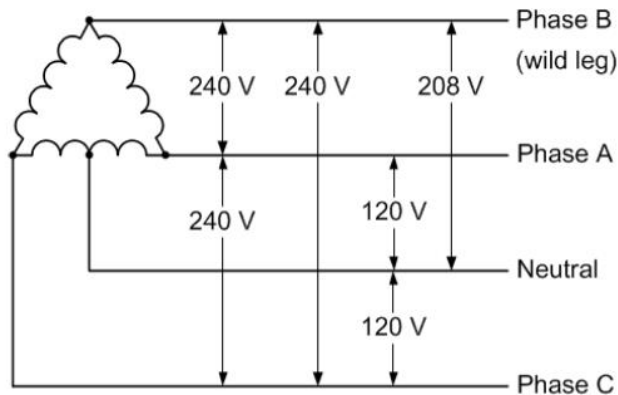

Also known as a high-leg or wild-leg delta system. Used in older manufacturing facilities with mostly three-phase motor loads and some 120 volt single-phase lighting and plug loads. Similar to the Three Phase Three Wire Delta discussed above but with a centre-tap on one of the transformer winding to create neutral for 120 volt single-phase loads. Motors are connected to phase A, B, and C, while single-phase loads are connected to either phase A or C and to neutral.

Phase B, the high or wild leg, is not used as the voltage to neutral is 208 volt.

#### Three Phase Two Wire Corner-Grounded Delta

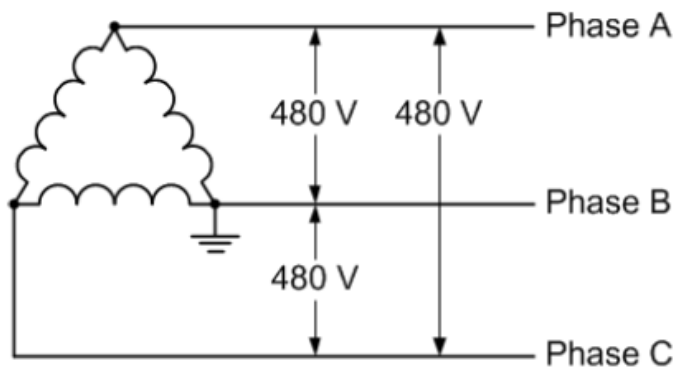

Used to reduce wiring costs by using a service cable with only two insulated conductors rather than the three insulated conductors used in a conventional three phase service entrance.

## International Electrical Distribution Systems

Description	L-N Vac	L-L Vac	Countries
1-Phase, 2-Wire 120 V with neutral	120	–	US
1-Phase, 2-Wire 230 V with neutral	230	–	EU, UK, Scandinavia
1-Phase, 2-Wire 208 V (No neutral)	–	208	US
1-Phase, 2-Wire 240 V (No neutral)	–	240	US
1-Phase, 3-Wire 120/240 V	120	240	US
3-Phase, 3-Wire 208 V Delta (No neutral)	–	208	US
3-Phase, 3-Wire 230 V Delta (No neutral)	–	230	Norway
3-Phase, 3-Wire 400 V Delta (No neutral)	–	400	EU, UK, Scandinavia
3-Phase, 3-Wire 480 V Delta (No neutral)	–	480	US
3-Phase, 3-Wire 600 V Delta (No neutral)	–	600	US, Canada
3-Phase, 4-Wire 208Y/120 V	120	208	US
3-Phase, 4-Wire 400Y/230 V	230	400	EU, UK, Scandinavia
3-Phase, 4-Wire 415Y/240 V	240	415	Australia
3-Phase, 4-Wire 480Y/277 V	277	480	US
3-Phase, 4-Wire 600Y/347 V	347	600	US, Canada
3-Phase <a href="#">4-Wire Delta</a> 120/208/240 Wild Phase	120, 208	240	US
3-Phase <a href="#">4-Wire Delta</a> 240/415/480 Wild Phase	240, 415	480	US
3-Phase <a href="#">Corner-Grounded Delta</a> 208/240	–	240	US
3-Phase <a href="#">Corner-Grounded Delta</a> 415/480	–	480	US

Note: regional variations may exist: if in ANY doubt, consult your Electrical Supply Authority.

## Amateur HF Band Plans

A.M. Frequency slots in Amateur HF Bands

All Frequencies in MHz

160 Metres: 1.885, 1.900, 1.945, 1.985 (USA)

1.850 (W. Europe)

1.933, 1.963 (UK)

1.825 (Australia - daytime)

1.850 (Australia - evening)

80 Metres: 3.530, 3650 (South America)

3615, 3625 (in the UK)

3705 (W. Europe)

3.670 & 3.690 (popular AM frequencies, Australia)

75 Metres: 3.825, 3.870 (West Coast), 3.880, 3.885 (USA)

60 Metres : 5.317

40 Metres: 7.070 (Southern Europe)

7.120, 7.300 (South America)

7.175, 7.290, 7.295 (USA)

7.143, 7.159 (UK)

7.125 (Primary AM Calling, Australia)

7.146 (Secondary and WIA Sunday morning Broadcast, Australia)

20 Metres: 14.286

17 Metres: 18.150

15 Metres: 21.285, 21.425

10 Metres: 29.000-29.200

6 Metres: 50.4 (generally), 50.250 Northern CO

2 Metres: 144.4 (Northwest)

144.425 (Massachusetts)

144.28 (NYC-Long Island)

144.45 (California)

144.265 (Los Angeles, CA)

Other AM Activity Frequencies

AM activity is increasingly found on a number of other bands, in particular: 5317KHz, 7143KHz, 14286KHz, 21425KHz and 29000 - 29150KHz.

There are several local AM nets in the UK on top band.

## FM Frequencies

For mobiles working into VMARS events, 2m calling in on 145.500MHz (S20) is usual, before QSY to a working frequency. At event locations where military equipment is in use, suggested FM "Centres of Activity" on VHF are 51.700Mhz, 70.425MHz (70.450MHz calling).

### VMARS RECOMMENDED FREQUENCIES

3615 Khz Saturday AM net 08:30 – 10:30

3615 Khz Wednesday USB net for military equipment 20:00 – 21:00

3615 Khz Friday LSB net 19:30 – 20:30

3615 Khz Regular informal net from around 07:30 - 08:30

3577 Khz Regular Sunday CW net 09:00

5317 Khz Regular AM QSO's, usually late afternoon

7073 Khz Wednesday LSB 13:30; Collins 618T special interest group

7143 Khz VMARS AM operating frequency

51.700 MHz VMARS FM operating frequency, also rallies and events

70.425 MHz VMARS FM operating frequency, also rallies and events

## Audio Topics

Using a power transformer for valve audio amps

Valve audio output transformers are rare as dooby horse droppings nowadays, or nosebleed expensive - so try a mains transformer as a switch hitter until the genuine substitute is available.

230v to 6v are a good bet; a 2 or 5VA size will be adequate for a few watts of audio, but don't expect hifi!

Primary Volts rating	Sec'y Volts rating	Speaker Ohms	Anode Resistance
415	24	8	2.40k
380	24	8	2.05k
230	24	8	735R
230	15	8	1.88k
230	12	8	2.94k
230	6	4	5.87k
115	24	8	184R
115	15	8	470R
115	12	8	734R
115	6	4	1.47k

How to work out any impedance value:

(1) Calculate the Primary volts divided by secondary volts to get the turns ratio, "TR"

(2) Square the value you calculated for "TR"

(3) Multiply this number by the loudspeaker resistance (commonly 8 ohms) to get the equivalent anode resistance.

For instance, consider a 115v to 5v rms transformer.

$TR = 115/5 = 23$ . Square this number:  $TR^2 = 529$ . Multiply by the loudspeaker resistance you want to use, say 16 ohms: Anode resistance =  $16 \times 529 = 8.464k\text{-ohms}$ .

Wire the loudspeaker to the low voltage secondary; the high voltage primary is the anode load.

HiFi it's not, but it will get you going until a proper replacement arrives. The iron in power transformers is designed for 50 / 60 Hz duty; you'll notice a degradation in the treble frequencies. Counteract this by using capacitors for treble boost (look up "tone control circuits", for example) on the primary side to lift the HF response; a bit of "cut and try" with whatever capacitors you have to hand will usually find a workable value. If you're a CW / Morse operator, you can peak up your preferred audio note (usually ~800Hz or so) with a resonance peak using parallel capacitors on the anode side, which will give you useful filtering and tighter receiver bandwidth gratis.

## COMMON DIELECTRIC (insulating) PROPERTIES TABLE

Material	E value (low)	E value (high)
Air (clean & dry)	1	1
Epoxy Resin	3.3	3.5
Formica laminate	3.6	6.6
FR4 PCB material, no copper	4.8	5.3
Glass	3.8	14.5
Mica sheet, no internal voids	3	9
Neoprene Rubber	4.1	6.7
Nylon	3.4	22.4
Paper	1.5	3.3
Plexiglass (USA) / Perspex (UK)	2.6	3.6
Polycarbonate (Plas-Glas)	2.9	3.2
Porcelain	5	6.5
Slate	7	7.1
Styrofoam	1.05	1.1
Teflon	2.1	2.1
Vinyl	2.5	8
Wood, dry and split-free	1.4	2.95
Water, de-ionised 18M-ohm	34	80

## Power tool Battery Terminal IdentificationA

Power tool battery terminals typically serve specific functions, and the labeling can vary depending on the manufacturer and model. However, here's a general breakdown of what the terminals you mentioned might represent:

- 1. LD (Load):** This terminal is typically connected to the load side of the battery. It allows the flow of current to power the device or tool.
- 2. LS (Load Sense):** This terminal may be used for sensing the load on the battery. It can help in the management of the battery system to optimize performance.
- 3. LE (Load Enable):** This terminal is likely used to enable or disable the load. It may signal when the battery is ready to provide power to the tool.

4. **T (Temperature):** This terminal is often used to monitor battery temperature. It can be critical for battery management systems to prevent overheating.
5. **C+ (Charge Positive):** This is generally the positive terminal for charging the battery. It connects to the positive side of a charger.
6. **+ (Positive Terminal):** This is the main positive terminal of the battery, used for both providing power to the tool and charging.
7. **- (Negative Terminal):** This is the main negative terminal of the battery, completing the circuit for both powering the tool and charging.