

Hot Iron # 115

End February / Start March 2022

Table of Contents

CQ-CQ-CQ.....	2
<i>HF interference and LED lamps</i>	2
The choke between Earth and Chassis.....	2
Morse decoders and all that.....	3
Transmitters.....	3
Si5351 Oscillators.....	3
Rugged MOSFET's.....	5
Receivers.....	5
Rush Boxes et al.....	5
Bob's VHF Super-Regen.....	7
Diode Mixers and the Cube Law.....	8
Transformer-less Double Balanced Mixers.....	8
Specs of modern receivers.....	10
Regenerative receivers: some questions.....	11
Power Supplies.....	14
An alternative approach to <i>smoothing</i>	14
Rectifier Diodes in parallel.....	14
Components.....	15
Electrolytic capacitor "reforming".....	15
Switch cleaner & Lubricant.....	16
Fault Finding when a meter won't help.....	16
Audio Topics.....	18
Forrest Cook's Code Practice Oscillator – sounds NICE!.....	18
The WORIO 6U8A Code Practice Oscillator.....	18
Introduction.....	19
Warning.....	19
Test Gear.....	20
Meter multipliers – and practical <i>options</i>	20
A new take on RF prototype boards.....	21
A few thoughts about Grid Dip testing.....	21
DC Analysis.....	22
Antennas.....	23
A "universal" HF antenna that needs no special earthing.....	23
A Mini Dipole for 80m.....	25
A possible money saving antenna option?.....	27

CQ-CQ-CQ

Frank Barnes W4NPN.net has recently shown some weird pages... but the index Frank compiled shows perfectly at:

<https://www.w4nnpn.net/w4npns-hot-iron-directory/>

...and Frank's Hot Iron back issue files are at:

<https://www.w4nnpn.net/hot-iron-directory/>

...where you can select the issues of Hot Iron for download, and the "standard" files and lists of various electrical / electronic data that I used in my working life.

I hope Frank is OK, and he's able to keep up his amazing archiving job with Hot Iron. Frank asked me some time ago if he could do this; it takes a massive load off me for which I am forever in his debt. Compiling, writing, drawing and issuing Hot Iron takes a lot of time, but I do it as when I was a "green" apprentice, my mentor Stan spent hours talking me through the intricacies of electrical and electronic Test Gear design and Maintenance; if I can pass on a few percent of his wisdom then I'll feel I've achieved something worthwhile.

STOP PRESS! 26th. February:

Frank has returned, and has resumed "normal service", thank goodness!

HF interference and LED lamps

As if the radio amateur's life wasn't hard enough, some cheap LED light bulbs create one holy hell of electromagnetic mush. I never thought I'd wish for the return of tungsten filament lamps, but at least they didn't radiate S9+40 of random mush! The moral is don't buy cheapest; look for EEC or (IF you can find any) "made in the UK" for at least some limit of radiated electromagnetic noise.

The choke between Earth and Chassis

If you look inside electrical equipment, washing machines being where I first saw one, you see a chunky toroid that is connected between the earth of the supply cable and the chassis of the equipment. I could see no rhyme nor reason for this component: my working life philosophy of "bonding" the chassis of all equipment would effectively short this inductor out, so it was time to talk to Stan (my mentor) and see if this was indeed the case. "I reckon it's a noise stopper: either to stop earth line noise getting *IN* or motor control noise getting *OUT*" quoth he, and I've never discovered which - if not both.

If we are making our own radio gear, then it is beholden on us to make it SAFE. In all fairness, you, the builder, might be the only (current) user and be aware of any "issues" you've chosen to ignore but... memory fades, and others may be present when you aren't. All this comes to light with the increasing use of "IT" gear in amateur RF applications: many of these equipments are fed by mains input filter sockets containing delta connected capacitors and a line choke in the earth connection, as well as common mode Line and Neutral chokes. My advice is to **bond any exposed metal that can become live under fault conditions** - be this for DC, 50/60Hz. And... considering "wall wart" power supplies - how do you know, beyond any shadow of doubt, that they can cope with a high DC or RF back voltage impressed on the output, with AC mains on the input?

I was always taught to deal with interference, earthing, leakage and similar matters on an individual basis - fix the fault, don't just fudge the consequences!

You can find a historical reference here:

<https://www2.theiet.org/forums/forum/messageview.cfm?catid=5&threadid=1794>

Morse decoders and all that...

I've seen it said that using Morse decoders - or encoders - is "not in the spirit of amateur radio". I consider this twaddle; indeed, Samuel Morse himself tried very hard to de-skill the telegrapher's job as far as he could, and I very much doubt he'd refuse modern silicon IT equipment if he had had it in his day.

The telegraphers of his day, after a few weeks of hearing the receiving equipment's relays clattering, discovered they could interpret the noise as code, much to Samuel Morse's frustration - he wanted his system to be private and secure with the receiver operators merely handing the customer a printed message, without the operator knowing it's contents. The operators began decoding intuitively and writing the interpreted code down directly; this proved far quicker and more economical than the primitive printing technology so became the accepted *modus operandi*.

Think too of those who cannot use a hand key or hear sufficiently - for whatever reasons - are they to be disallowed on the airwaves with CW? As far as I'm concerned, if an amateur stays within the regulations governing amateur operation, I don't care if he uses a bent nail or a mainframe computer to send and receive signals, be they CW, AM, FM, or anything in between. Indeed it is very much "in the spirit of amateur radio" for technology to be tried, explored, and used to advance the hobby - thus we progress and amateur radio is enhanced.

Transmitters

Si5351 Oscillators...

From Dave Benson, K1SWL, and very much appreciated in light of the current problems in acquiring the Si Labs Si5351 chips...

"I've been using the Silicon Labs Si5351 frequency generator IC in my homebrew project over the past 3-4 years. For those not familiar with it, it's a tiny 10-pin IC with two Phase-locked loops inside it. A single PLL can be used to output two separate signals divided down to any frequency from 8 kHz to 125 MHz. Unlike a 'wide-range VFO' IC of a few years ago, these outputs are clean enough to use in our transceivers. I'm using two separate outputs to furnish the receiver Local Oscillator and the transmitter output frequency for a superhet CW rig. Only one of the two outputs is active at a time. On transmit, the receiver LO is turned off, so there's no big signal appearing at the receiver output. There's a learning curve involved in using this device, since it's controlled over a serial interface. It's not an insurmountable barrier, though. I'm commanding the IC from the Arduino 'C' environment, and library code examples are available for it.

Anyway- the Si5351 IC recently became unobtainable after a fire at the foundry facility. I had taken to using an Adafruit Si5351 module measuring only 0.7 x 1.2 inches and was surprised that they could continue to supply the modules.

The bigger surprise- they'd begun using a 'reverse-engineered' (read: pirated) version of the IC with a flaw. The first figure shows what the output should look like on a spectrum analyser.

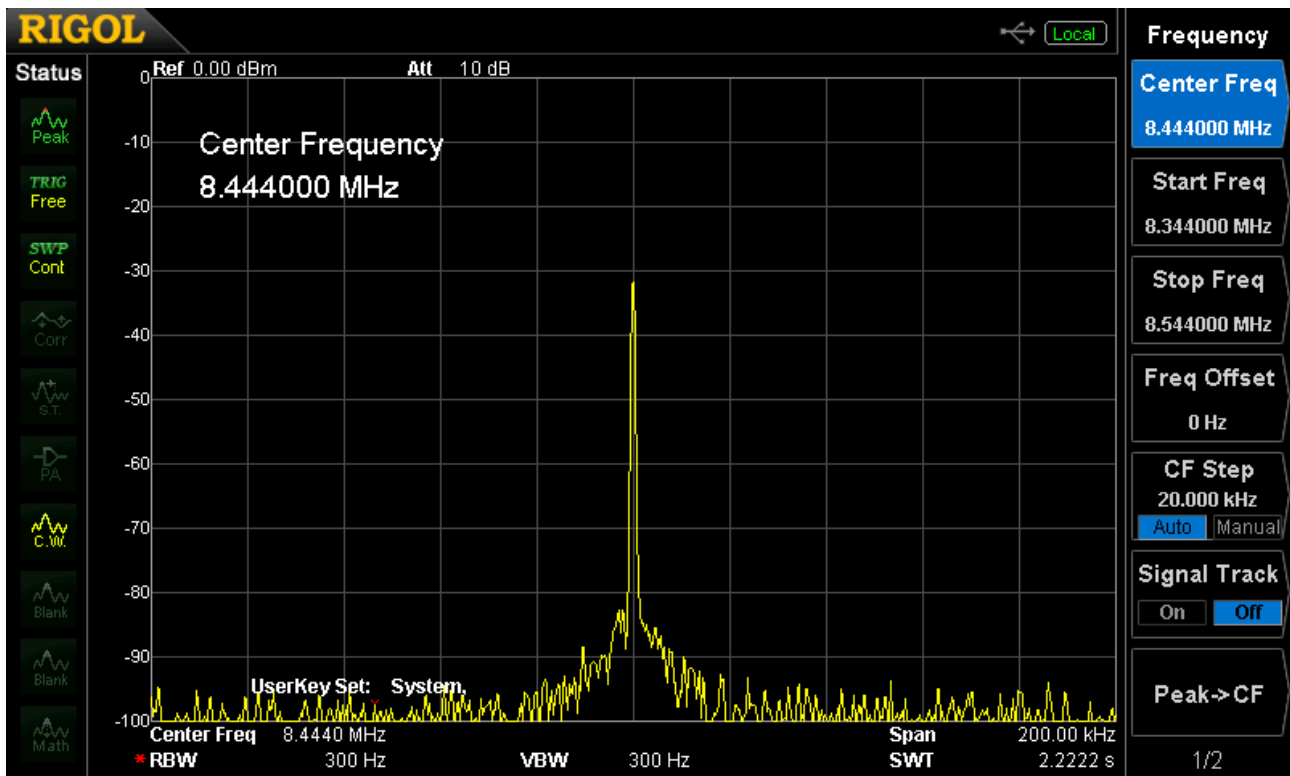

The second figure shows what I received. I embedded one of the Adafruit modules in an 80M rig. I was surprised to find the output off by 30-some kHz on a frequency counter. It's normally within a few hundred Hz even without calibration. I was further surprised to copy an HF aviation weather service from outside the amateur band. Additionally, any given amateur signal could be copied every 32 kHz. As if this weren't bad enough, I conducted a brief QSO and was doubtlessly transmitting outside the band.

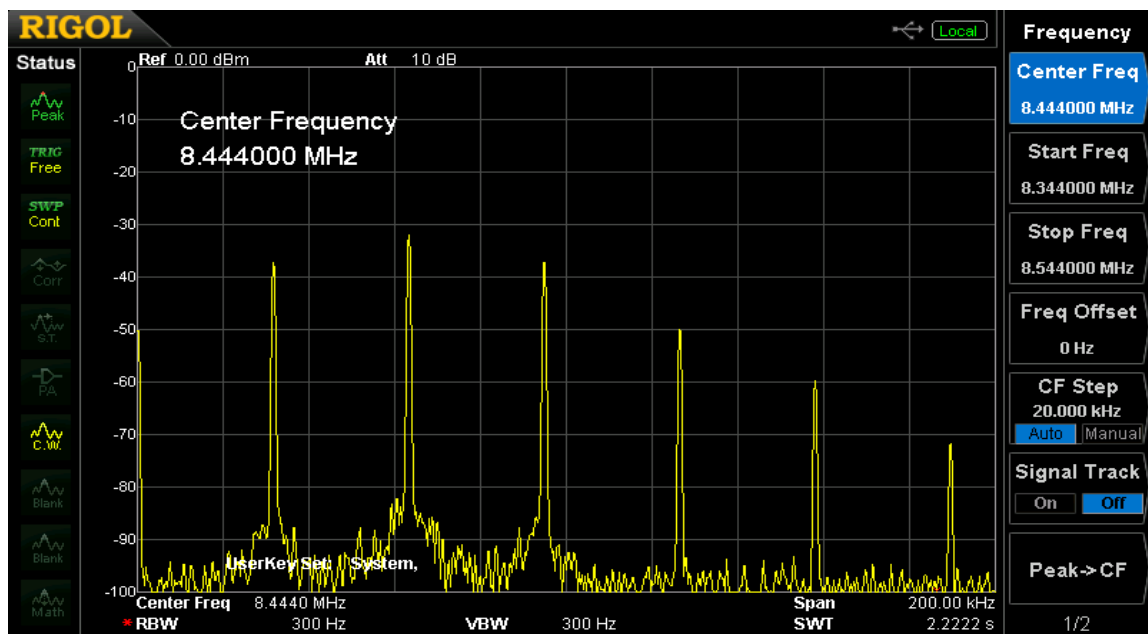

My discussions with the Adafruit support engineers got me nowhere. I talked to three different engineers over several weeks. I don't think any of them knew what my spectrum analyzer plots meant. They did finally concede defeat and sent me several replacement modules. Those were also bad.

I'm grateful to an RF engineer who weighed in on my forum topic with an explanation for the behaviour. In reverse-engineering a new version of the IC, the 'Spread-Spectrum' feature was 'ON' by default rather than off. The 'fix' was anticlimactic- I added a snippet of code to my firmware."

```
-----  
Wire.beginTransaction(0x60); //turn off spread spectrum  
  Wire.write(149);  
  Wire.write(0x00);  
  Wire.endTransmission();  
-----
```

Many, many thanks to Dave for this contribution: this is the heart of amateur radio – not just the technology, but the free sharing of information, either as the written word or “on the air”.

Rugged MOSFET's

Technology, as ever, rolls relentlessly on: silicon devices in very “trying” or “must not break” applications are giving way to alternative technologies, and amateurs not wishing to be forever replacing “finals” in their transmitters would do well to read up on silicon carbide power devices. These promise to be a positive step forward in the “withstand anything” capabilities so beloved by thermionic devotees in transmitter finals, so well worth a look. Check:

https://www.wolfspeed.com/products/power/sic-mosfets?gclid=Cj0KCQiA09eQBhCxARIsAAYRiylbuFNfe2zxCQEPC3bAv0BfiGVwrbCTJOIpU-4cHWG-L6nJi06iBEEaA1eqEALw_wcB

Receivers

Rush Boxes et al...

There are very few users of the super-regen on the amateur bands, the method is virtually unknown and even if it is known, it is shunned as it has such a bad reputation. Well, you should know that the super-regen is alive and well and used in literally millions of applications world wide, in commercial and industrial applications like security RF service, RF remote controls, low cost telemetry and a million and one other uses.

Here's why you shouldn't be frightened of using a super-regen:

1. It's just another version of a regenerative receiver, yes, the sort you wouldn't think twice about building;
2. It will NOT spew out huge amounts of interference if you use a simple RF amplifier;
3. It is simple, sensitive and reliable;
4. It can be made very selective if used with a crystal filter i.e. as part of a superhet style design;
5. They are good fun to use, easy to get going, very forgiving, (in semiconductor form) and are very capable;
6. Can be a major part of a simple VHF / QRP transceiver packed into in a very small portable unit;

7. Can open up the whole world of VHF for pennies.

Having said that, below is a cracking good design for a 6m receiver that can readily be adapted to 10m, 2m, 4m, etc. from Bob Liesen WB0POQ:-

“Nice to get your post. I have been playing with “rush” boxes for quite some time. Here is one I have been playing with of late. The audio reflex is an idea I borrowed from some simple BC designs. It seems to increase the AF output a bit and extends the freq response somewhat.

Most of my designs use BJTs, but I have done a few JFET designs as well. Someday I want to try a dual gate MOSFET, but my experience suggests that a high enough Ft, along with low noise are the presiding factors in these things.

One interesting note on JFET designs....I don't know if you have access to the QST magazine archive, but in the Aug 1968 issue, Doug DeMaw built one called the “Connecticut Bond Box”. I'll be darned if I could get the detector to work. I suspect the schematic may be in error, and it should be a grounded gate design, but the author usually presents pristine designs plus in those days, QST contained very few errors in their schematics. (Anybody got a “Bond Box” schematic I could analyse for Hot Iron? Please email it to me! Ed.)

Here is an interesting thing that happened to me a while back when working on one. I was using my work Metcal soldering station. At one point in testing I was changing some component values, and the circuit stopped working. No audio output, not even the no signal hiss.

I juiced the generator up to 1mV output.....nada....dead.

At this kind of turn, I typically go back to the last working values, which I did.....nada..... dead as an 807 with an open filament.

I worked on this for an afternoon. I was about to reach for the ball-peen hammer, but turned the solder station off first. The circuit came alive! Turn the Metcal back on....dead...

Metcals use RF to heat the tip and having the iron near the circuit was somehow killing the regeneration.

Crazy.....

Bob

Bob's VHF Super-Regen

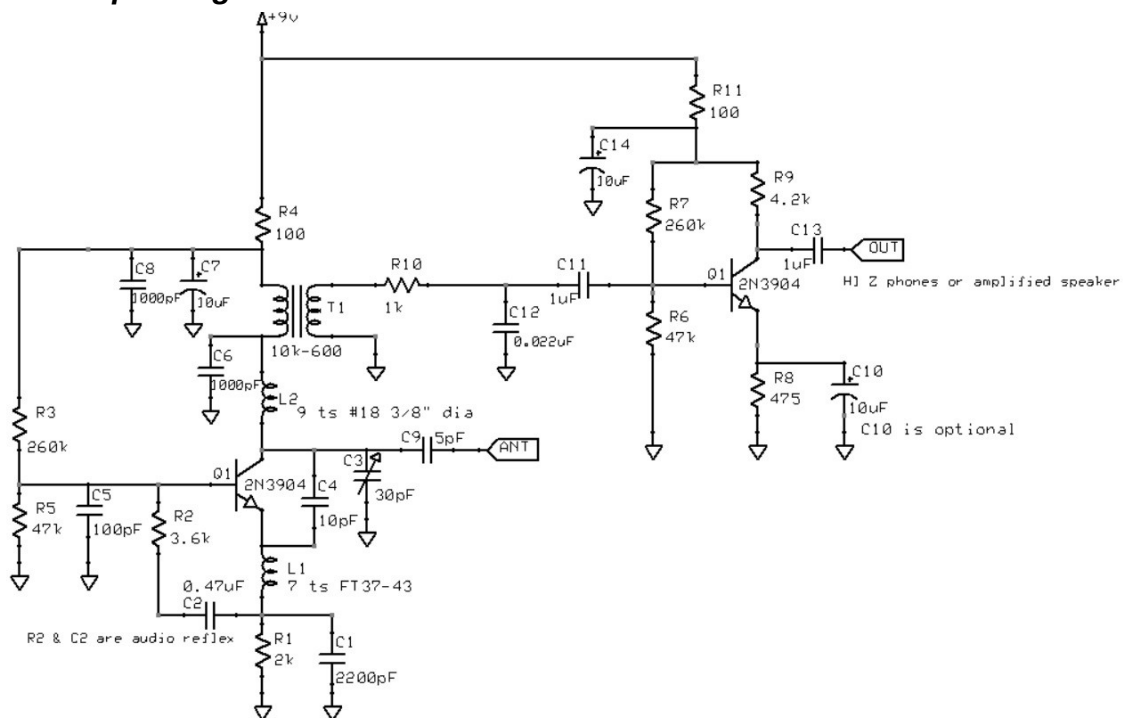

This is a design I've used myself; it's a real performer - the circuit warrants a few notes. First, note capacitor C5 in the base connection. This is used to shunt RF to ground; but it allows audio from R2 + C2 to pass into the base, giving a useful boost to the audio output. This is reflexing and was well known in the early days of solid state devices: every device had to work hard for it's living. I prefer a "gimmick" antenna input capacitor in place of C9, usually a wire close alongside or one turn round)one of C4's leads (doesn't matter which, try either and see which is best!).

C4 is the Colpitts feedback capacitor (it's a common base Colpitts oscillator) and with C3 form the tuning section with L2. The crafty amongst us (ahemm...) will use a screw type piston trimmer here, as you get lovely fine tuning and repeatability.

Other than that, the circuit is a standard: the dead give-away for a super-regen is the choke in the emitter (L1). This choke is in no way critical; grab a ferrite bead and bung some turns on, and the beast fires up a treat. It would be nice to experiment with different inductances / formers but the thing just goes with a sniff of inductance, I've run this common base design up to 1300 MHz with no bother using a BF180 or similar UHF device - recall that in common base the frequency capability of a transistor is vastly more than running in common emitter (virtually no Miller effect).

I like a grounded base un-tuned pre-amp (below) to feed the antenna signal into the super-regen, this prevents the super-regen from splattering noise across the band, but for local QRPpp ops it's a bit of overkill. Be careful when wrapping the input wire round the emitter lead; the open end can short to ground, so tuck it out the way. The ZTX 326 is in no way critical - it's just my favourite VHF transistor, try anything you have to hand.

Common Base RF stage (NPN) 100 MHz

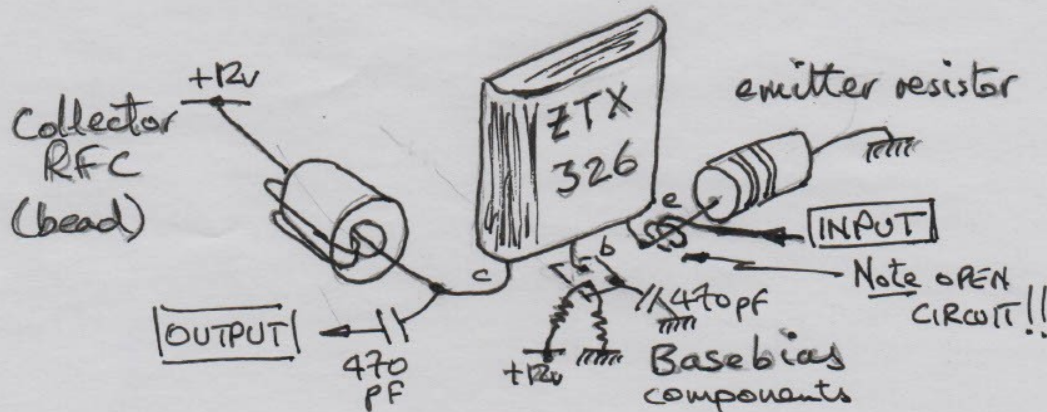

Now note the transformer in the super-regen's collector. It serves several purposes: it's an output impedance "shifter" to match the collector circuit; it's also an RF choke, which is necessary to maintain oscillation at VHF frequencies. You might note though that audio is also present at the lower end of the emitter choke, as is the quench frequency - if passed out to an audio amplifier via a two stage low pass filter (simple R/C is fine, set for top cut at 5kHz or so - just make sure you use a high value of series resistor, 22k or more, which mandates a high input impedance audio stage like a jfet) the results are nearly as good as the collector transformer design Bob uses. If you go for the emitter audio output, remember to put an RFC in the collector to replace the choke effect of the audio transformer. You don't need much inductance: just bung a good few turns on a ferrite bead, on any old bit of ferrite or core, or even round an iron nail. It will most likely work fine!

Diode Mixers and the Cube Law

Viktor Polyakov's design for harmonic mixers and the cubic law – is this design (or any other...) better with matched Ge diodes for a closer approximation of the cubic response?

It would make an interesting experiment to compare, say, a Polyakov mixer made with (1) 1N4148 diodes; (2) HP5300 Schottky diodes; (3) OA81 Ge diodes (cheaper and more easily obtained than 1N34's) that have been roughly matched by the "ohm-meter" method. Test for linearity with varying input signals.

Maybe someone has already done this? I have searched but to no avail; however, if Viktor Polyakov thinks it best to approximate a cube law response, I'm certainly not going to argue!

On the subject of mixers...

Transformer-less Double Balanced Mixers

Packaged or home made, diode ring Double Balanced Mixers (DBM's) whilst usually a good choice have several issues: they need "Hemi-V8" local oscillator power to slam the diodes in and out of conduction; they have transformer which, unless wound very carefully (as in production

manufactured windings, for instance), will include an imbalance that can't be adjusted out; they need 50 ohms on every port, from DC to daylight; they feature significant losses that require gain stages (and the consequent noise and overloading distortions) to make up.

DBM's were derived from valve / tube circuits, which proved good candidates for commercial radio gear: if memory serves me, Eddystone Radio used them in Marine service "Trawler band" MF transmitter and receivers. The circuits featured a balance adjustment which meant a ship's "sparks" could tweak the balance control a touch to give basic receivers a bit of carrier, or an unmodulated carrier for CW.

For amateur applications, the circuits below bear a distinct similarity to the innards of such mixers as the SA602 / 612, or the MC1496. These devices are much more developed than these earlier circuits, but for simple home made radio jobs the forerunners are usually adequate and feature some big advantages. (1) They need *no transformers*; (2) they are somewhat tolerant of mismatched ports; (3) they have decent gain with low noise (it tends to cancel due to the balance - if you're lucky). They would make a simple direct conversion receiver possible with very low component counts for mobile gear, too. I must admit that discrete semiconductors are my choice over IC's as you can repair the circuit with a (near) substitute in the event of disaster - try that with a blown IC, without one to hand! Anybody got any "unusual" balanced mixer schematics, please let me know.

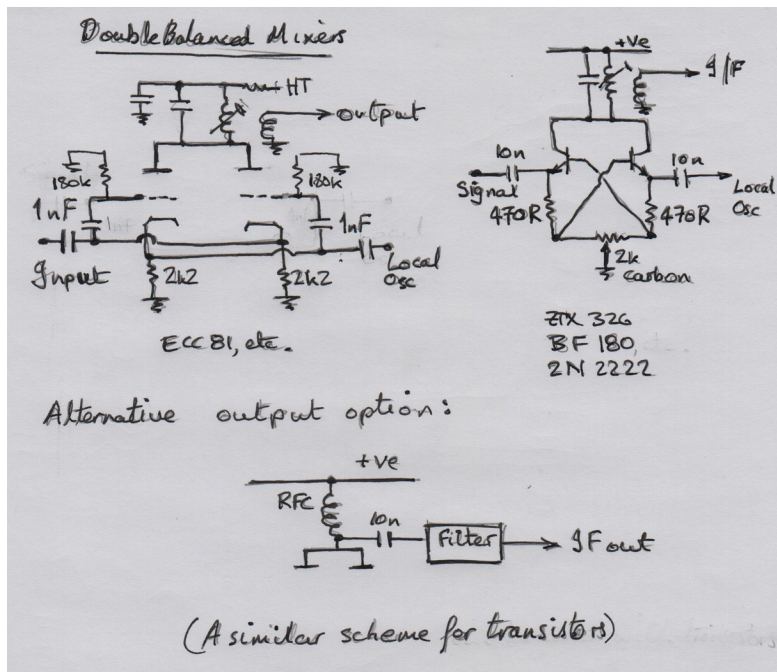

Specs of modern receivers

Modern mass-produced solid state receivers are (probably) tested in a production facility, lab gear providing the signals, measurements and power. What are considered excellent figures are given in specifications, and, yes, no doubt under those “lab” conditions, are probably met. Now let’s switch to the typical amateur station...

The antenna(s) feeding the receiver can easily deliver 10mV of RF; a quoted rejection ratio of 60 dB (considered a respectable figure) for IF breakthrough is not adequate ($\text{dB} = 20 \log_{10} [A_v]$ where A_v = the gain or attenuation) then 60dB represents 10 μ V of signal! Such strong signal interference in the amateur station isn’t at all uncommon: really powerful broadcast stations, D/F systems and the like *even though non local* can be present such powerful signals.

The more astute will have noticed I quoted “solid state” above; and for good reason. Whilst valve / tube technology is more demanding in terms of size, power and the like, vacuum devices just do it better. The CW DX man, hunting that tiny fraction of a μ V signal, really needs to be looking at 120 dB of rejection; if possible, 130 - 140dB is required. Modern gear quote 50, 60 or exceptionally, 80dB of rejection of spurious signals is not really that good: there might be other local amateurs in close proximity pushing hundreds of mV’s into his receiver input. 140 dB or more is his only hope if he’s to work faint CW DX.

This isn’t a modern scenario: in 73 Magazine, December 1967, E. Conklin, K6KA brought this to light. He quoted 10,000 amateurs in California all within ground wave distance from each other! This brings to mind a special receiver designed for the Royal Navy by GEC (UK). It had proven rejection of 130dB+; synthesizer tuning of a 1600kHz IF design, with two low gain RF stages using 12AU7 double triode cascode connected followed by a 12AT7 twin triode balanced push-pull mixer (similar to that presented in this issue) very carefully constructed and shielded. Superb though solid state might be, it struggles to match this level of performance, even nowadays.

It is to be pointed out though, figures like this rely on engineering to a level not normally available to the amateur; nor at an amateur price. The points to be made - often neglected in amateur

construction - placing a really effective (auto controlled AGC with adjustable time characteristics) attenuator at the input: silicon diodes are superb in this role; as is purity of the local oscillator; shielding; balanced circuitry wherever possible; vacuum tube (or possibly FET's) in the signal path; low ripple power supplies; adequately decoupled circuits at every stage; build for good dynamic range (again, vacuum devices can score here).

All this points to hybrid designs being a definite step forward for amateurs wanting the best performance at practical costs and complexity.

Regenerative receivers: some questions

I have had some emails about regenerative receivers and how they relate to the more unknown corners of design I've mentioned previously in Hot Iron. Home constructors still find excitement in hearing a signal on their home made receiver and want more about how to improve their circuits.

It won't do any harm to discuss the different regenerative receiver "morphologies": there are roughly three to consider, each with it's own pros and cons.

(1) Manually controlled regenerative receiver

This design features a control to adjust the amount of feedback; advanced too far, the circuit will oscillate. It is the general idea that the circuit will be "stimulated" by the incoming carrier and lock onto the carrier, thus we have the "autodyne", "synchrodyne" and "homodyne" circuits which demodulate A.M. signals and reject others present at the input by the Q factor of the oscillator circuit and the low pass nature of the audio amplifier following the detector / oscillator stage.

These designs need a feedback, tuning and volume controls as a minimum.

(2) Automatic feedback regenerative receivers

These are the circuits above, with a diode rectifier circuit sensing the condition of the oscillator section - if the oscillator is in fact oscillating, the diodes rectify the oscillations, producing a DC voltage which is used to limit or "back off" the bias to the oscillator, thus automatically holding the circuit just on the point of oscillation, or (depending on bias) only just oscillating. This is done by tweaking the bias point of the oscillator to ensure slight oscillation or hold the circuit right on the point of oscillation.

There have been a couple of these "auto regen" circuits in Hot iron; Viktor Polyakov and other Russian designers have come up with ingenious means of applying auto feedback control. These designs don't need a "regen" control; just tuning and volume; they might have a switch to allow CW to be demodulated by biasing the circuit just into oscillation; or A.M. by holding the circuit just before the point of oscillation.

(3) Super-regenerative receivers

Imagine, if you will, a regenerative receiver as described in (1) above, but with an "electronic" motor turning the feedback control up and down so the circuit bursts into oscillation thousands of times a second. This means the receiver goes through the maximum gain point of the circuit repeatedly - at a rate well above human hearing. You would hear the incoming signals amplified and demodulated to the absolute maximum capability of the circuit.

Super-regens need a tuning control, and (because of the immense gain available) a squelch gate if you don't want ear shattering white noise when the signal shuts off.

You can see the virtue of each design: manual control is the simplest, auto control is a fascinating area, not fully explored on HF as far as I know; super-regens have their devotees (me included!) and are an amazing way to get onto VHF, UHF, microwave bands very easily and simply.

A magnificent article about regenerative receivers, homodyne, synchrodyne, autodyne *et al* can be seen at:

<https://www.thevalvepage.com/radtech/synchro/section1/section1.htm>

Auto control regens have featured in Hot Iron previously; for those who like experimenting, the following is a cracking good circuit:

<https://www.cool386.com/arc/arc.html>

And Viktor Polyakov's adapted by S. Kovalenko

"This is the tuned radio frequency receiver for short wave (25 meter band, 11.7...12.1 MHz). It was created as experimental design for further experiments with the autodyne synchronous receiver (see [Polyakov V. T. Autodyne synchronous regenerative receiver. - Radio, 1994, N 3, page. 10.](#)). The circuit diagram is shown in Figure 1.

The first RF stage is a regenerative Q multiplier circuit with fast automatic regeneration control.

The input resonant tank composed of the loop antenna WA1 and capacitors C6 (the trimmer capacitor), C7 (the variable capacitor), C8 and C9. The resonant tank circuit has very high quality factor Q within the working band (11.7...12.1 MHz), so the effective height of the loop antenna can be up to several tens of meters. An antenna with this parameters can receive very weak signals. The sensitivity of this shortwave receiver is limited by the noise of the transistor VT1, so it would be better to use in the first stage a low-noise RF transistor.

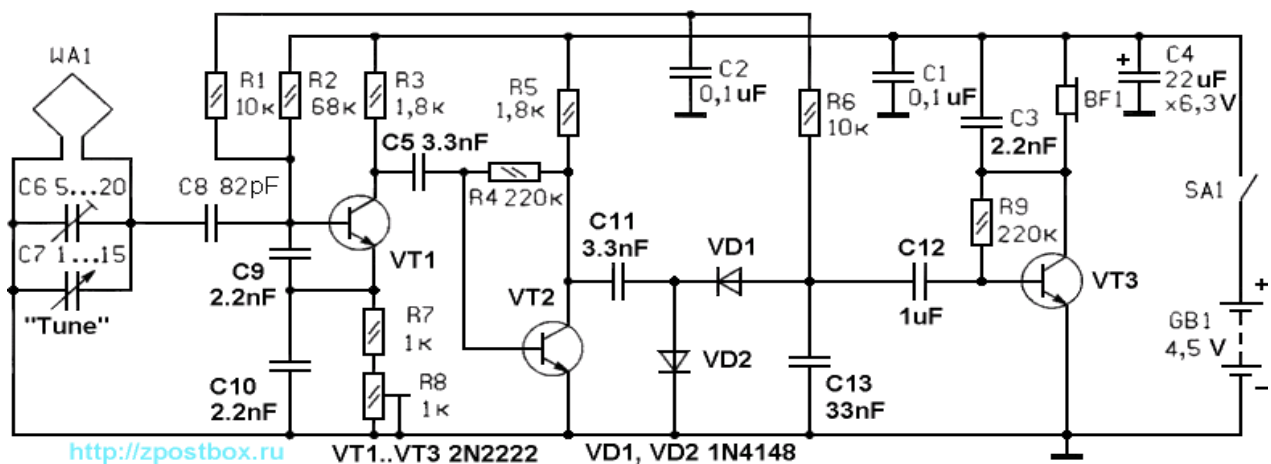

Figure 1. The circuit schematic of the regenerative shortwave receiver with automatic regeneration control.

C6 - 5..20pF, trimmer capacitor; C7 - 1..15pF, variable capacitor; C8 - 82pF;

Transistors VT1-VT3 - 2N2222; $h_{FE} \min = 50$, transition frequency $f_t = 250 \text{ MHz}$.

The automatic regeneration control circuit includes the second stage of HF amplifier (the transistor VT2) and the diode based detector (C11, VD1, VD2, C13). The resistors R1, R2 and R6 provide a bias current for diodes VD1, VD2 and for the transistor VT1. From the output of the detector the DC signal corrects the regeneration of the regenerative stage, the AC component of signal goes through the capacitor C12 to the one-stage audio amplifier based on the transistor VT3. The headphones BF1 is the load of this audio amplifier. The resistance of the headphones is about 1600...3200 ohms. The output power of the audio amplifier is about 1 milliwatt.

The resistor R4 provides a feedback biasing for the transistor VT2, and the resistor R9 does the same for the transistor VT3. Match the resistor R4 to get the voltage across the collector of the transistor VT2 equals to half of the supply voltage.

The coil of the loop antenna WA1 is frameless with a diameter of 200 mm, it consists of 2 turns of copper wire 1.5 mm (AWG 15), the step of the winding is 10 mm. To make the loop antenna rigid, we can fix the turns with each other with pieces of dielectric material. The antenna can be made out of a ferrite rod, but it would work much worse.

The variable capacitor C7 can be used with larger capacitance, for example, 4...200 pF, but it requires a small ceramic capacitor 15..25 pF connected in series with C7. A varicap can be used for tuning, but it will reduce the quality factor Q of the resonant tank circuit, and the varicap will require an additional voltage source of 15..25 V.

Setup the regenerative stage on the edge of oscillation by matching value of the capacitor C10 and by adjusting the trimming potentiometer R8. This potentiometer should be high quality, else its noise will interfere with the receiver. If you haven't a high quality potentiometer, you can replace it with a resistor (match its value). Use the trimmer capacitor C6 to adjust the frequency band of the receiver.

The consumption current of this regenerative receiver is about 3 mA, so with a battery 3R12 the receiver will work for 1000 hours.

There are two shortages in this regenerative receiver - the tuning of the regenerative stage is depends on the supply voltage, and if there is a massive object in vicinity of the loop antenna, its quality factor goes down.

The reception quality of this radio receiver is better than a superheterodyne radio receiver because of the narrow band, the directional properties of the loop antenna, and total absence of an image frequency interference. But this advantages are useless when there is a powerful radio signal in the working frequency range.

S. Kovalenko”

An modified version of this receiver is:

http://www.antentop.org/016html/016_p85.htm

You'll find another idea for auto control on page 79 of:

<https://worldradiohistory.com/Archive-Poptronics/50s/59/Pop-1959-04.pdf>

I don't know how effective these are, I've never tried them!

Power Supplies

An alternative approach to smoothing

I once had to build some gear into an existing 19 inch rack in a Faraday shielded dark room, used for photodiode testing. I had the transformer, a magnificent toroidal design from our own CRT scan coil section - toroids being a very uncommon transformer in the 1960's - and a chunky bridge rectifier, built from discrete stud diodes; but the issue was the smoothing.

The transformer delivered only just enough volts to run the silicon diode bridge at the current required, and because of existing rack space whatever I used for smoothing had to be as small as I could make it. I experimented with many μF 's of electrolytics, but unfortunately the output regulation was inadequate and the inrush current way too high; on no load the voltage floated too high. A three terminal regulator was no solution: I didn't have one, they were not to easily obtained in the 1960's, and what's more, I didn't have the voltage headroom for such luxuries!

A quick chat with mentor Stan paid dividends: he pointed me towards the "black hole", our dusty, dark, cellar store - for a 250mH toroidal inductor, from a stock that had been ordered for electroplating duty, nominally 10 amps, just what I needed. "But, surely, 250mH isn't anywhere near big enough inductance" I asked in my innocence? "It'll be fine, put a 10 μF electrolytic in parallel with it, positive terminal towards the bridge positive output" quoth Stan... I was staggered: I'd never seen a smoothing choke with an electrolytic in parallel in a power supply.

"Simple", says Stan: "that L and C are resonant at about 100Hz; with a good quality electrolytic for decent Q it'll smooth more than enough. Check it out on the bench first, as electrolytics can have wide value tolerances, look for the electrolytic that gives lowest ripple into a dummy load then fit it into the rack module - it'll just go in with luck". "But surely" says I, "the electrolytic won't tolerate reverse bias in a resonant circuit?" "The electrolytic will never see any reverse bias, look at the circuit. It works by exchanging energy with the inductor as a tank circuit filter. It rejects the 100 Hz ripple, but DC passes with ne'er a blemish".

As ever, Stan was on the money: good smoothing, decent regulation, in a much smaller volume than I'd ever expected. Job Done!

P.S. Yes, the resonant smoothing did work... for a couple of months. The electrolytics in those halcyon days were not as nowadays; they "dried up" quickly in "ampy" jobs; that's why when refurbishing any vintage gear, the first job is to replace the electrolytics - keeping the cans and connectors so you can put modern capacitors inside to preserve the aesthetics of the job.

Rectifier Diodes in parallel

Current sharing is the problem: one diode of the paralleled devices will hog the current. This makes this component heat up - and the forward volt drop of a silicon junction falls at 2 mV per $^{\circ}\text{C}$ so the "hogging" device attracts even more current, leaving the parallel devices doing little if anything.

The answer? Add a low resistance in series with each diode (incidentally, this is how RF power transistors work: they are multiple paralleled devices, with resistors in each emitter to force current sharing), typically 0.1 ohm to 1 ohm. The diodes will share the current equally.

The maths behind this is to estimate of the slope resistance (almost never quoted, so you'll need a curve tracer) and add an equal amount of external resistance. This (after a lot of abstruse maths - if you don't believe me, try it) results in the minimal loss for effective current sharing.

Components

Electrolytic capacitor "reforming"

Though I can't honestly recommend "boiling up" old electrolytics like this, it's a technique I saw years ago that crops up every now and then; the vintage radio and TV restorers love this sort of thing, so here's the gist of the job.

The most important component in these reforming devices is a strong, stout wooden box. You need this to contain the electrolytic being "reformed" - they have a nasty habit of going BOOM! when you least expect it, and the box keeps the shrapnel down. Seriously, exploding electrolytics are bl**dy dangerous!

We ran devices like this with the electrolytic on the end of a long, long run of two core cable, the cover box being in the factory yard well away from anybody. 4700 μ F charged up to 500 (or more) volts is a potential bomb if all the stored energy is released in one sudden burst. Don't take chances!

Right, if you choose to build and run a device like this, be it on your own head: they are very simple but rely on mains power to generate high voltages, so must be fed as per your local electrical regulations i.e. via double pole isolation switches with appropriate contact gaps (or use an isolating transformer...? Ed.); and fit bleed resistors that are self indicating. An open circuit wire wound resistor doesn't tell you if it's gone open circuit - so I advocate using 5 watt filament lamps, as used in cooker hoods, rated 5 watts 230 volts working. They represent roughly 10.5k Ω each, and the filament glow tells you they are functional.

The circuit uses a Greinacher voltage doubler - an ideal job for salvaged microwave oven 2 μ F / 2kV capacitors? - fed via a current limiting lamp to double up to roughly 600 volts, a string of 5 watt HV zeners (1N5338 type, 100 volts and 50 volts typically) clamp the output to the appropriate rating of the electrolytic being "reformed". You could jumper unwanted zeners rather than removing them, to make life easier? In parallel with the zener string are three 5 watt 230 volt lamps in series: these bleed the "reformed" electrolytic and indicate via filament glow that they are functional.

The 100 Ω resistor in the return lead to neutral is for current sensing: 1 volt across 100 Ω representing 10mA. In practice, the meter indicating the current is set to 10 volts DC full scale, connected up with insulated leads and clips and is NOT TOUCHED during the "reforming" process. The electrolytic to be "reformed" is connected up with robust secure connections, noting polarity (!!!), and the power very briefly applied - if no disaster, then apply the power for a couple of seconds, noting the current reading. It will be a good few mA's to start with; but as the plates "reform" the current will gradually reduce - ideally to a low value of mA's.

If you see a steady (and usually rapid...!) rise in the current - shut off the power! That electrolytic is destined for pastures new... i.e. in the BIN, not your current refurbish project!

"Don't expect miracles" is good advice. "Reformed" electrolytics are usually OK for a while; but they have a habit of failing after a period of running, probably the internal losses evaporate what's

left of the electrolyte - the result is typically a loss of μF 's with a corresponding rise in mains buzz or audio fading, if not a complete breakdown and the corresponding smoke followed by major clean-up. But - if it restores a beloved vintage bit of kit, with all original parts, then all's well with the World. Good Luck!

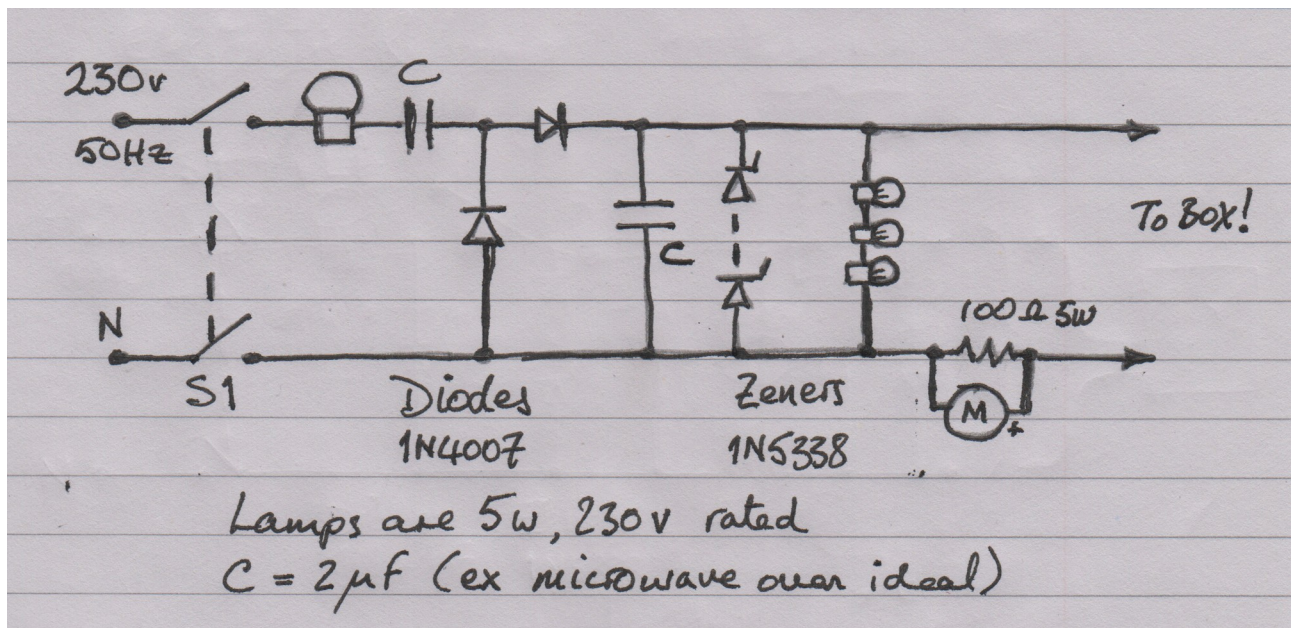

Note: two silicon diodes in series, connected in parallel with the current sense resistor, cathode of the series pair to the +ve. end of the meter, is a good idea to stop the meter movement getting zapped. A digital multimeter may be more robust, but a dead short electrolytic will zap a digital multimeter meter just as effectively as a mechanical movement meter - Ed.

Switch cleaner & Lubricant

A neat dodge that can really help clear those noisy pots, notchy rotary switches, bad contacts and the like... buy a small bottle of "white spirit" (turpentine substitute or white kerosene) and drop into the bottle a scant half teaspoon of petroleum jelly ("Vaseline") and replace the cap.

Now, shake, baby, shake! Mix the petroleum jelly in completely, then apply **very sparingly** with a cotton bud or cocktail stick to the offending gizmo. Work the mechanism a good few times back and forth and the job's a good 'un! Keep the fluid firmly capped until needed on the back of your bench.

Fault Finding when a meter won't help

I was called out at some god-forsaken hour of the night to see a fault the night shift had: the 3 phase transformer's soft-start resistors, made up of 1kW firebars, glowed a healthy red hot on power up of a high voltage power supply, rated at 15 kV, 3 Amp DC on a ETE back face aluminium evaporator running a 270° magnetic wrap-around electron gun source. My first test was to disconnect the primary of the 50kVA HV transformer: now the firebars stayed cool, so nothing odd on the 415 volt 3 phase side of things. Reconnect the primary, disconnect the secondaries and try again - yes, the fault was there again, even on no secondary load.

Obviously the fault is in the transformer, so disconnect the ends of the delta connected primaries and ohms test each winding, making sure the primaries were all genuinely isolated, to avoid parallel paths disrupting the measurements.

OK; all three primary winding showed equal DC resistances, so out with the 500 volt Megger and test for primary shorts to earth. Nothing! All primaries - and the terminal boards, wiring and anything else that could somehow affect the primaries - all tested clear.

Now I had real problems. No doubt there was a fault inside this transformer: no spare (50kVA transformers are big, expensive, and heavy!) for an swap out, but nothing, absolutely nothing could be found in error with the instruments - or equipment - we had.

By now, dawn had broken, the day shift coming in, and found yours truly in front of a cup of tea, desperately trying to figure out a way I could positively, without any doubt, condemn this transformer and ask the plant manager to buy another transformer without my proving beyond a shadow of doubt that the transformer was faulty. I knew the answer and it's unprintable here!

Enter Rob P., an epitaxy process engineer and the conversation rounded to my problem. "Oh, you need that article I saw in TV Servicing last month, about finding shorted turns in windings", quoth Rob P. Intrigued I asked Rob P. to draw it out on paper, and thus enlightened asked Mike P. the Technician, to drag out a 1 kV DC HV supply from the Ion Implanter spares.

I made a changeover switch from some copper bus bars, brass bolts and a bit of Tufnol for a base and handle, and dragged the completed assemblage round to the transformer. The circuit was simple: an 8uF oil & paper capacitor to the switch moving blade; one fixed pole to the charging HV supply with a series current limit resistor, the other pole to a winding on the suspect transformer, all the negative returns commoned to the negative of the power supply.

Thus the switch, in one position, charged the capacitor up; in the other position, the capacitor charge was dumped into the primary of the suspect transformer. I tried it on a known good single phase transformer Mike P. had "procured" (doesn't pay to ask Technicians too many questions...!), and yes, the primary on the good transformer (secondary open circuit) rang like a bell on the 'scope.

Now try the evaporator transformer primary: not even a full cycle! The other primaries looked similar under test, but since they are all magnetically connected, one dud primary would affect the others. It was a "gotcha" moment; Rob P. went off to his Gemini Epitaxy reactors with a big smile, Mike P. gave me a knowing wink, and I prepared my £15k purchase request for the big man to choke on when he came in at 'executive' start time, 9.00 a.m. (ish).

The replacement 3 phase transformer was delivered next day, the evaporator up and running a treat and still is as far as I know; when the day shift operator came back on shift after his 4 days off, I asked him to describe any odd things he'd seen before the original transformer blew. "Err, yes, a full charge of aluminium blew out the crucible when de-gassing; went with a right thump, I can tell you - took ages to clean the chamber and crucible".

Well, that sorted it all out: and I knew for sure what blew the transformer. The sudden burst of aluminium vapour in the vacuum chamber was a dead short across the transformer secondary, the corresponding primary surge current melted the winding wire enamel and voila, shorted turn(s). They are usually in the dead centre of a winding - that's where it's hottest and the enamel melts.

Now you know how to find a transformer shorted turn, a fault no multimeter can ever diagnose. Happy Hunting!

Audio Topics

Forrest Cook's Code Practice Oscillator – sounds NICE!

Once again, Forrest brings the golden tones of valve audio to the shack: how come valves do the job with that added touch of gentility and etiquette so sadly lacking in some transistor audio projects?

~~~~~

I thought you might be interested in a project I did a few years ago, it's a one-tube code practice oscillator that is built around several modern split-bobbin transformers.

It's a relatively simple project and is easy on the ears.

Details are here:

<http://www.solorb.com/elect/ha>

*[I've reproduced part of Forrest's article below, follow the link above for the "full trip"... Ed.]*

## **The W0RIO 6U8A Code Practice Oscillator**

(C) 2015, G. Forrest Cook, W0RIO (formerly WB0RIO)



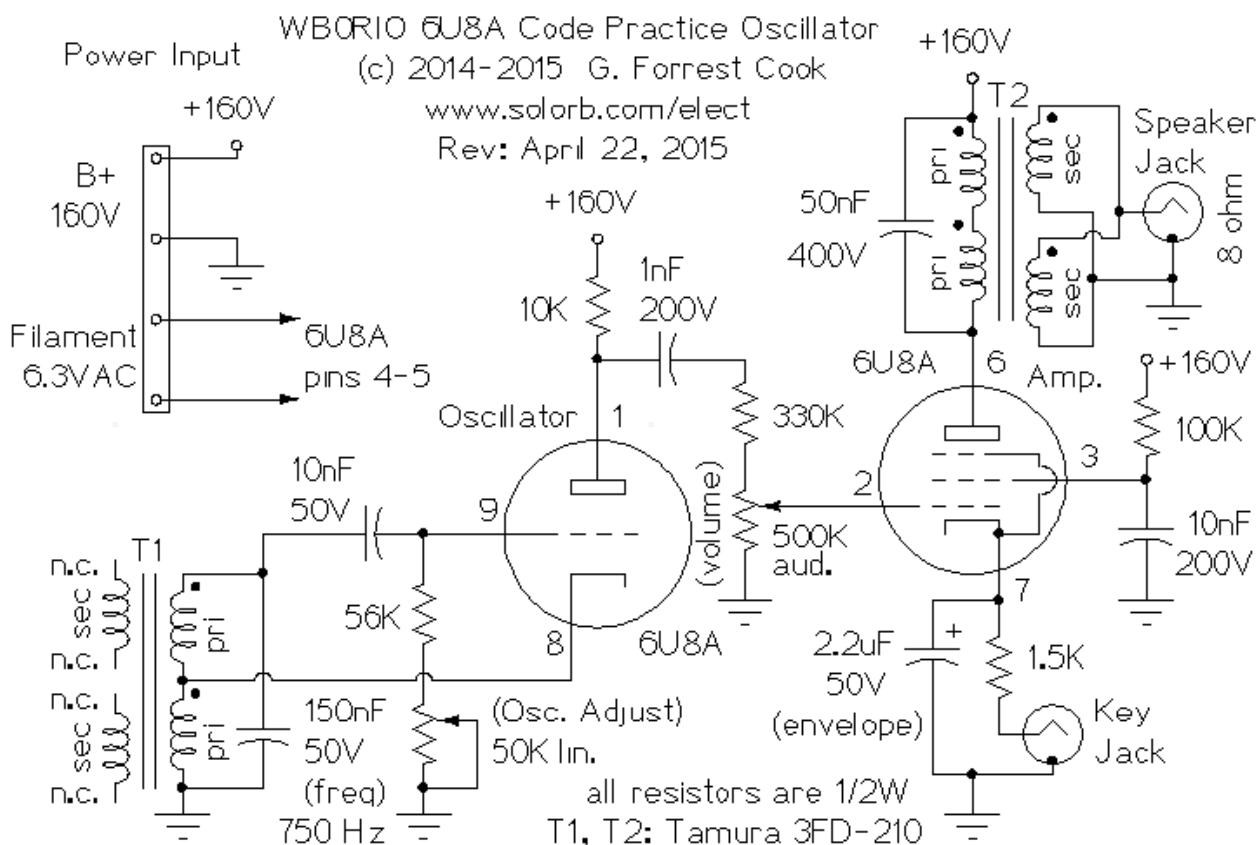

## Introduction

This circuit uses a 6U8A triode/pentode tube as the heart of a code practice oscillator (CPO). It is simple enough to be built by a beginner and would be a good introductory project for those who want to experiment with vacuum tubes.

The circuit produces a hi-fi sinusoidal output with a wave-shaped envelope for minimal key clicks. These features reduce operator fatigue and make the CPO easy to listen to for extended periods. For contrast, see my solid-state [Smooth Tone Clickless CW Sidetone Generator](#) project.

The circuit is designed to work as a stand-alone unit. The design is modular and it would be fairly easy to adapt it to most tube transmitters as a side tone oscillator.

This simple [Power Supply for Vacuum Tube Experiments](#) (set for 160VDC) provides power for the code practice oscillator.

## Warning

This project involves the use of potentially lethal high voltages including 120 VAC and 160 VDC. The project should only be taken on by someone who has experience working with high voltage circuitry. The power supply should always be disconnected and the power supply capacitors should be discharged when working on the code practice oscillator. The circuit's chassis should always be connected to the AC power ground when operating.

*[An EF82 or similar will substitute nicely for the 6U8A; and the transformers are any dual 110 volt primary / 3, 5 or 6 volt dual secondary rated 1 – 2 VA... Ed.]*

# Test Gear

## Meter multipliers – and practical options

In many cases, amateurs inevitably discover the old fashioned moving coil meters are a far better option than digital instruments; true both have their places in the RF world, but I far prefer watching that meter needle indicate a peak than some dancing digits or LED's!

One area that a moving coil meter far outweighs a digital is in low power field operations, "SOTA" and the like - because a moving coil meter needs no battery, a device of the Devil which uncannily will die just at that crucial moment!

One place moving coil meters can score is the instant recognition the needle position gives: it's like looking at the fingers on a clock, the image is all you need to tell you the time. I bet you have a clock face image in your mind when you look at a digital time readout, yes?

Any which way, here's a trick I learned when using battery power in extreme low noise measurements: it's offset voltmeters to indicate battery charge. Think of a sealed lead acid battery, full charged, it's at 14.2 volts or so: flat at around 12 volts or so. The volts under 12 are irrelevant; I wanted to see 12 to 15 volts, spread right across the meter scale.

Easy-peasy; use an offset circuit, to feed a nought to three volts meter! A 12 volt zener did the job, a 3k resistor made up from 3 x 1k metal oxides. I didn't, however, have a 12 volt zener: Stan reckoned a "Vbe multiplier" circuit would do the trick for me: thus the job was done with trimmer pot, an NPN transistor and a few minutes juggling. Job done! Full scale = full charge, flat = zero scale, at a glimpse. That did the trick in the Faraday shield darkroom; the tiniest light to see the meter was enough, no LED digits and stray light.

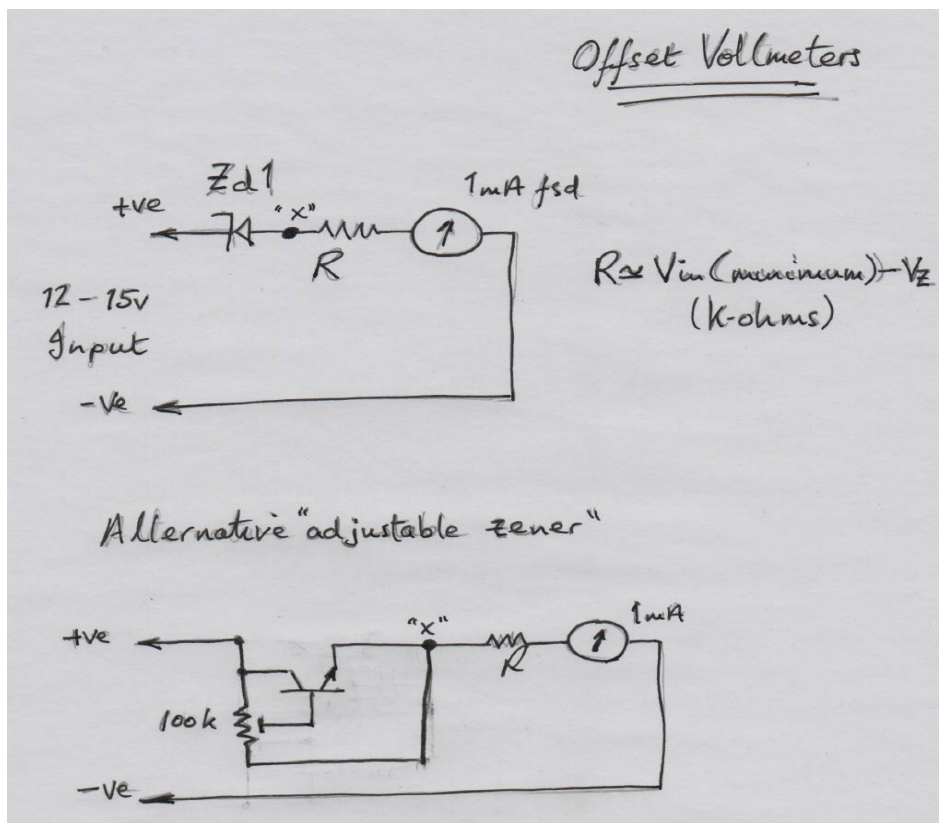

### **A new take on RF prototype boards**

Tom McKee brought this to my attention, many thanks, Tom!

<https://miscdotgeek.com/a-new-prototyping-pcb-for-qrp-homebrew-radio/>

Here's a glimpse from the website, but personally I like wide "buss" rails - especially grounds - so I'd use strips of pcb material mounted above the "islands" at right angles, anchored by small bits of wire to appropriate pads: this design would be good for close implementation of circuits, as the ground busses so installed could form shields around sensitive circuit areas.

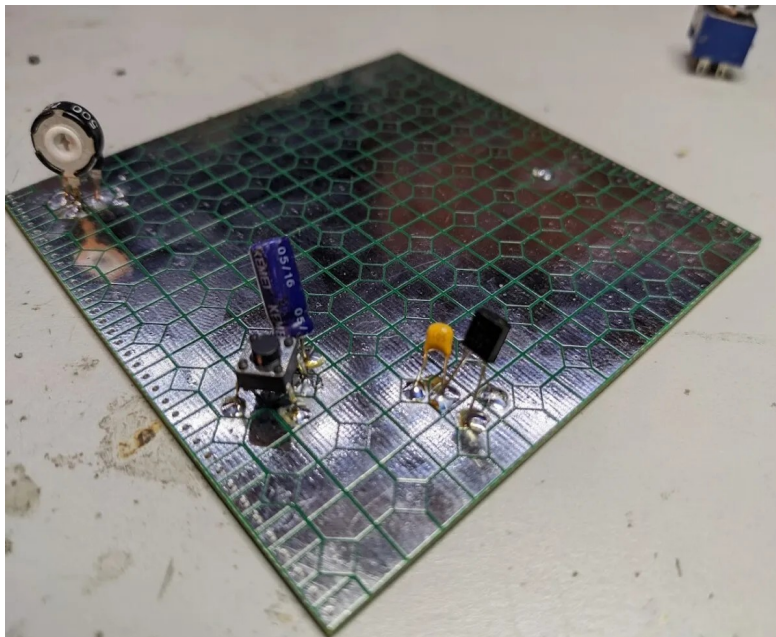

### **A few thoughts about Grid Dip testing...**

When an amateur gets a grid dip meter, he's well on the way to constructing successful circuits, using his own designs or bits and pieces culled from existing designs. At first glimpse, the Grid Dip Oscillator is a wonderful bit of kit - and so it is - if you keep in mind some basic operating methods. Grid Dip Oscillators have been mentioned previously, but to answer a few questions I've had, I've found three main issues.

Question: *"I can't seem to get a dip with this toroid inductor and a parallel capacitor?"*

Toroid circuits are notoriously tricky to "dip": you can't easily get good magnetic coupling into the circuit as the toroid keeps the flux inside the material. The good point is this, though: very "loose" coupling is a good idea when chasing resonances! The Toroid "problem" can easily be resolved with a simple "link" coupling, a turn of wire through the toroid, brought out and the bare copper ends of the loop twisted together. The GDO coil is brought close to the coupling link and adjusted for a "dip" then progressively moved away from the link. The resonance indication becomes sharper and sharper, thus giving a good indication of resonance.

Make sure too the capacitor you've used to test the resonance is a reasonable value: keep to mind that at resonance,  $X_C = X_L$ ; 300 ohms at  $f_0$  (resonance) is a good start... you could try to resonate



100pF with 1 Henry of inductance ( $f_0 = \sim 50\text{kHz}$ ) but I doubt very much you'd get a clear resonance with these components, representing a reactance over 31k ohms!

Question: *"I get dip indications at many frequencies, which is the "real" one?"*

The coil of the GDO emits RF (albeit at very low power) into anything around the coil; this can be over quite some distance (as seen in Q.1, above). Thus anything that can absorb energy from the coil - screening cans, chassis plates, wiring, and so on - but these "stray" dips are nothing like as deep or broad as the fundamental resonance. Look for the real "show stopper" dip, then withdraw the GDO coil away, as described above. This should show a very strong dip even at a distance, indicating the fundamental resonance.

Question: *"I get dips on related frequencies, like 2 x, 3 x, and so on?"*

You are seeing the harmonics of the complex circuit you've created by injecting RF into a circuit by bringing a GDO coil in close proximity to a resonant circuit. The trick is to look for the lowest frequency dip that is deepest.

Imagine in your mind's eye what's happening here, you have two resonant circuits in close proximity; one is the circuit under test, the other is inside the GDO. As the frequency of the energy exciting these double tuned circuits become close, the coil under test influences the GDO oscillator resonance, and vice versa: only at the true resonant point do the two oscillators exchange maximum energy between them. This is what creates the fundamental and harmonic dips!

Resonant circuits can't resonate below their fundamental; harmonics - whether the GDO oscillator or the resonant circuit under test - "ring like a bell" on any integer multiple of the fundamental, be it 1 x, 2 x, 3 x, and so on. The higher the harmonic, the shallower the dip, is fundamental physics but be aware that it depends on the magnetic properties of the coil and core - so you might not see any solid dip beyond the third harmonic. If the GDO waveform is a clean sine wave, that is; if it's squared off for instance, the third harmonic might show nearly as deep a dip as the fundamental but the frequency always gives the game away.

Antennas too can be dipped via a link loop, and the same as above applies. The dips can be as deep or incredibly tight (often seen when dipping an antenna with high Q loading coils employed). The resonances will be easily apparent too for those building multiple (harmonically related) dipoles for instance.

Happy Grid Dipping!

### **DC Analysis**

You can rapidly decipher a non-functioning circuit by checking a few DC voltages around the circuit, and, as I was vigorously taught, check the power supplies first! Some circuit diagrams will include "normal" DC voltages at various points, and a very big "thank you" to the designers who took the time to do so. Most faults will quickly show awry DC conditions; you know, for instance, that (assuming a simple common emitter NPN amplifier stage) the collector should be a reasonably high +ve voltage; but certainly not at full +ve rail volts. Similarly, the emitter should be a low voltage, and indeed might well be at ground potential. The base should be somewhat higher than the emitter, by the base-emitter voltage,  $\sim 0.55\text{v}$ .

You should keep in mind however that some circuits can radically change when an input signal is present, or when an oscillator (for instance) is oscillating: the DC conditions change quite dramatically. In these cases, it's a good idea to disable the input - short it to ground, via a 0.1 uF if a DC bias exists on the input - or unplug the coil or crystal to stop the AC conditions swamping the DC you're looking for. Make sure that doing this doesn't cause any disasters afore you do it! If a fault exists, disabling the input can force damaging circumstances in the circuit, so check first on (if possible...) lower supply voltage / current. A series resistor or our old friend, a filament lamp, can be a help here.

One additional test you can do is to check that a transistor can actually switch; the voltages you have seen might be feedback from another source. I often use this trick as a quick check, but be careful: you will be forcing the transistor to switch and this may not be a good idea! Check as best you can the circuit to see if forcing the transistor to turn off is harmless.

Those of you with valve / tube experience will probably know the effect of touching a metal screwdriver blade to the grid terminal; you inject a fair bit of hum and noise. Shorting base to emitter is similar and can indicate faults.

You'll be monitoring the collector voltage to ground, ideally with a clip to leave your hands free, and deftly touch a (insulated handle!) screwdriver blade tip to both base and emitter, shorting them together. This forces the transistor to turn off, thus the collector voltage (assuming the collector load isn't open circuit...?) will rise to the rail voltage, thus proving that the transistor will actually switch.

You can check long tail pairs this way by monitoring the collector and the "long tail" link; you'll see a swing in the voltage. By shorting with the aforementioned screwdriver pin 2 to pin 3 of a "741" op-amp (or any op-amp with the same pin out) you can force the output to "balanced" condition, or, if the op-amp is an audio amplifier, hear a significant change in output. Be aware though, this can throw some circuits into oscillation, so be brief and be careful!

This trick works on both NPN and PNP bipolar transistors, enhancement mosfets (gate to source in common source connection), IGBT's and the like, but BE CAREFUL. You're forcing what is effectively a fault on the circuit, so be sure you've got your dull lamp current limiter or similar in the power feed, just in case.

## Antennas

### ***A "universal" HF antenna that needs no special earthing***

From Pete Millis, M3KXZ who writes...

*Hi Peter,*

*The antenna I currently use is a home brewed version of the Bushcomm Mil-1.*

*This is fed with a 9:1 unun with one side going to a 16m long wire, with a load or termination resistor and a further 8m of wire beyond that. The other side of the unun goes to a 4m long wire which is grounded. The 9:1 unun and the load or termination resistor provide a good match to 50 Ohm coax right from 160m to 10m with SWR ranging from 1.0:1 to about 1.8:1. At most points SWR is below 1.5:1.*

*I have wound a couple of ununs. One is on a BN43-3312 binocular core and the other is on a tiny BN73-202 binocular core. They both work really well. The BN73 seems slightly better.*

*The load resistor is a 470 Ohm thick film resistor by Telpod.  
(Try your own with 470 ohm metal oxide resistors, wired in series / parallel. Ed.)*

*The grounded end is just grounded by attaching to 160mm aluminium tent peg.*

*I have been setting the antenna up at between 1.6 and 2.0m above ground, either horizontally or as a very low inverted V. Just really making use of convenient supports like gorse bushes or stringing between tree trunks.*

*I've attached a sketch showing how I've been setting it up. In the absence of enough trees then I just slope the long end down to the ground and secure it.*

*Now, it's generally understood that a load or termination resistor will eat up power and with be no good for QRP.. I've read probably 15% when the match is bad, others suggest maybe 25%. But that's a fraction of an S unit, and means I don't need to use any tuner and I don't need to make any antenna adjustments when changing bands; a massive plus for me as I only get 15 to 30 minute operating sessions. This antenna I can set up in 1 minute flat and just get on the air.*

*What has really surprised me is that I have had far better results with this than I've previously had using an end fed sloper with my Elecraft T1 atu, or the ATU on my KX1. This is operating from the same locations.*

*As well as having a terrific QSO with W3DF yesterday while running my little 5W, I had a similarly great one with NY2PO last week and have had plenty of other great QSOs across Europe. And reverse beacon network has reported spots of my CQs far and wide. Really happy considering the limited time I have had, and that I've been getting out at the worst times of the day.*

*Attached are the sketch of how I've set this up, and also a drawing from Bushcomm of other ways to set up.*

*I'd be interested to hear your thoughts!*

*73, Pete M3KXZ*

### ***Pete's QSO notes using the antenna...***

*I set up in the woods with the antenna strung up at 2m above ground level and had a couple of terrific QSOs with my 5W.*

*First was with IK3XJU, Roberto on 30m who was fairly close at 675 miles (1080km) with a closing band and very heavy QSB.*

*The second QSO was on 17m with W3DF, Dan, just before I was about to go QRT due to freezing cold hands and needing to pick my wife up from rehearsal for the Christmas pantomime. This QSO was amazing. Dan is in Westminster, Maryland - a distance of 3674 miles (5878km).*



Really very happy indeed. Considering I only had 20 minutes to operate, being able to set this antenna up in about 1 minute and not have to worry about a tuner and antenna adjustments is fantastic.

73 de M3KXZ

Pete's antenna is shown below. Neat, simple, effective. What more could you ask? It's always thought that resistors lose power; yes, this is so, but power lost is related to the current running through them. In this design, the current through the resistor adds to the radiated field by flowing into the "post resistor" element - the resistor losses are far less significant than in a fully terminated antenna like a VEE or rhombic.

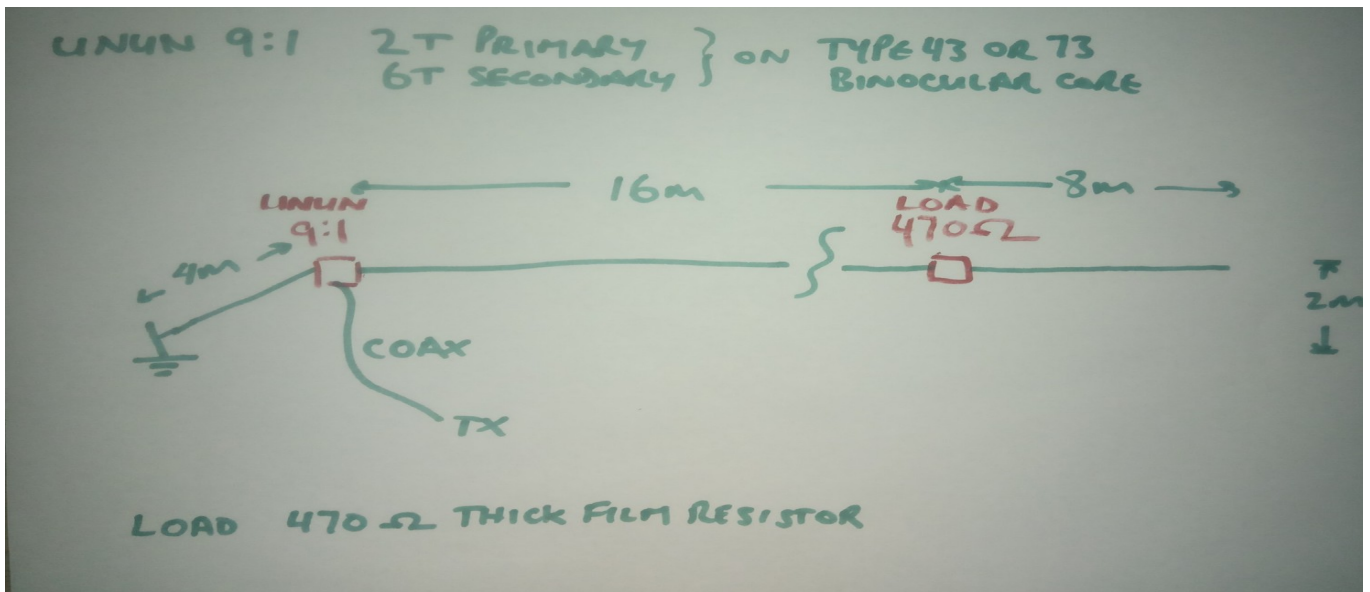

### A Mini Dipole for 80m

Folded dipoles for 80m are nothing new but it's such a good "fit" into typically small UK households it bears repeating, and my favourite method of winding high Q coils is shown below.

Eternal discussions arises about such "loaded" dipoles having narrow bandwidths of resonances, but for those who are squeezed into a tiny garden (or "none" in many cases) such designs can make or break an effective station. One tip: use the heftiest copper wire you can get your hands on: lower losses, tougher construction, higher Q. Polypropylene strain "struts" keep the coil from deforming in tension: make them of the heftiest polypropylene you can get your mitts on if it's at all windy where you are.

Another point of conjecture is the use of PVC covered wires for antennas. The PVC coating does increase the capacitance by a few percent; this modifies the resonance a little, but the massive advantage of structural strength pays big dividends. One point with PVC covered wires, often overlooked, is that they offer significantly easier connection to a guy rope or other end harnessing method, as compared with open or enamelled copper wire. The stranded core gives much superior flexibility too, for those in very windy or coastal aspects. Though it's a rapidly fading memory (hopefully...) the acid rain that used to drench the Northern UK was effectively blocked by PVC wire covering; it did get somewhat brittle after a year or two, with the sulphuric acid getting at the bonds in the PVC; the same goes for polypropylene guys, nylon monofilament "secret" end

insulators, PVC waste pipe used for loading coil formers and the like. Remember too that sunlight UV will attack the bonds in a lot of plastics, so best look out for “UV resistant” types if you want a good few years out of plastic used in antenna construction.

Note the technique of using string alongside the wire in winding the loading coils; it automatically spaces the wire as winding progresses and a few dabs of super glue as the job progresses helps keep everything in shape. I wind on top of greaseproof paper, this allows peeling the string off after the assembly is slid onto a plastic pipe or slotted perspex “combs” to hold the coil turns firm. Once the string is peeled off, the whole coil can be slathered in home made polystyrene dope for a permanent job. My simple coil winding gizmo is made of wood from a broken shipping pallet, the string is the sort butchers use and the wire is scrounged from transformer winders as tail end bobbins, they don't like starting a winding with doubts as to whether the wire will run out before the winding is completed!

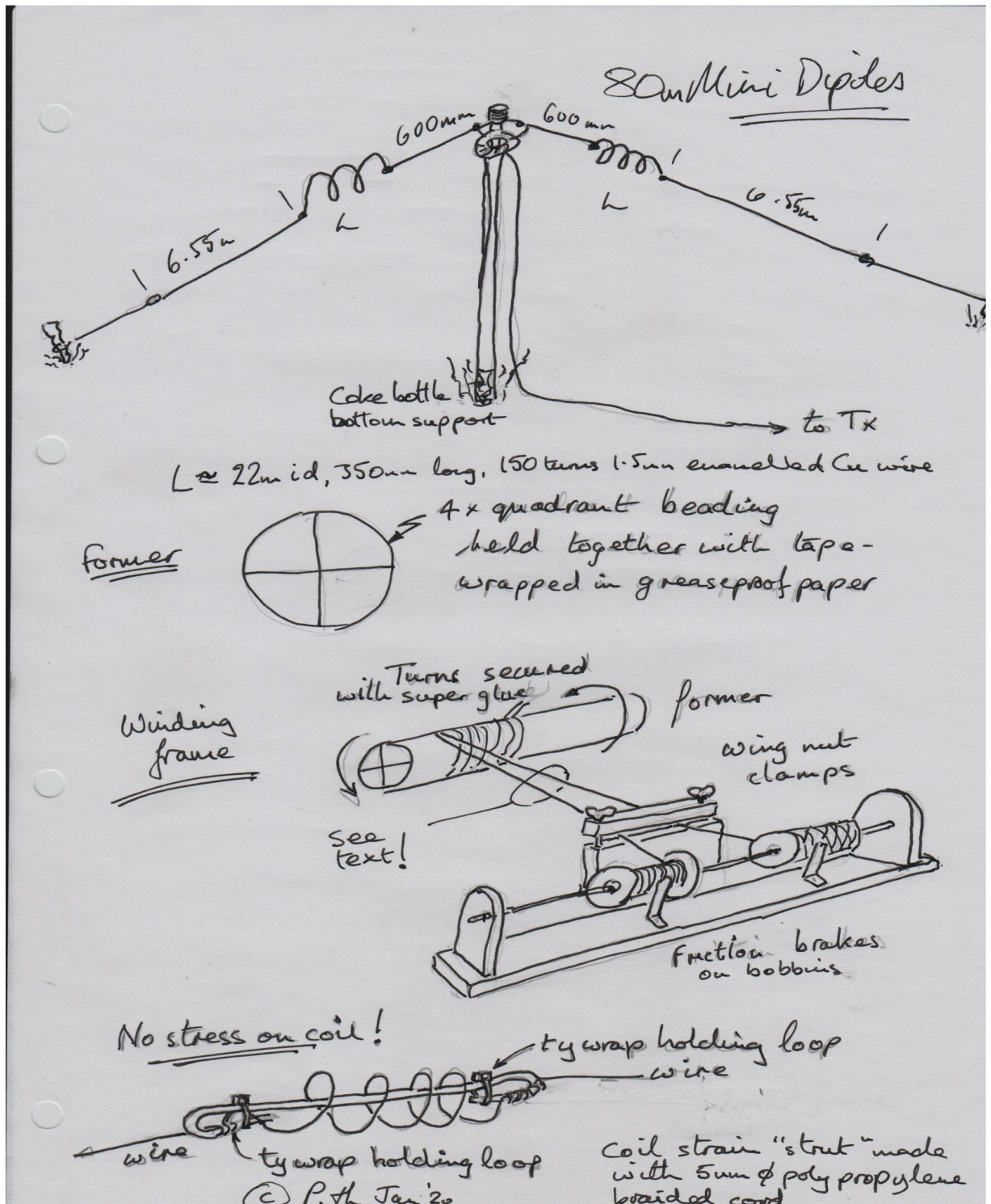

### A possible money saving antenna option?

It's a fact: RF power travels in the few outer mils of a copper wire. Fact. It's because the inductance in the centre of the wire is far higher than the outer, so the RF naturally chooses to travel in the lowest impedance region! It's often suggested that receiving antennas are made from Copper-weld wire, which is steel inner with a copper coating, designed for MIG welding (amongst other more esoteric methods).

So why is it that all the high power RF generators I've worked on over the years had resonant coils made from very hefty copper pipe: Admitted, in most cases, it was to allow cooling water to the load coils (inductive heating) or for generating very high energy VHF plasmas for etching silicon wafers.

Copper pipe lends itself beautifully to power RF coil construction with brass compression fittings, ideal for making repairs - water does eventually create pinhole leaks in copper, it's the nature of the beast - and demountable connections for load changes, and the like.

I've never heard of a RF transmitter running more than a few watts using anything but solid copper; though above roughly 50 watts small bore copper pipe, silver plated, is *de-rigueur*. It should be perfectly feasible to use copper coated steel wire for power RF, silver plated or not, as the steel will most definitely increase the core inductance!

Which leads to the question: is it because micro-bore copper pipe is cheap and easy to use, or is it that the ancients just made it big when RF power was required, and we've simply followed the pattern all down the years, and bunged in the hefty copper?

I'd like to hear from anybody who has - or is willing to try- in the nature of RF experimentation, copper weld wire in a transmitter tank circuit running 50 watts or more. I can't promise everlasting fame, but it would make a decent difference to those winding coils for the lower bands, bless 'em!

A useful skin depth calculator is at:

<https://www.allaboutcircuits.com/tools/skin-depth-calculator/>