

Hot Iron

Spring 2011
Issue 71

Contents

**The Compton-Twofer
Competition & SSTV
Ideal RX - Cary/Cam
Digital Sig Gen
Fault finding
Snippets:-
Veroboard
Unstable band switch-
ing
Lighting efficiency
Squealing Mendips
Absorption Wavemeter
QRP Convention
QRPiC 2011**

The Walford Electronics web-
site is also at
www.walfordelectronics.co.uk

Kit Developments

Reports from those who have added a **Kilton** to the **Yeo DC RX** are very encouraging. Both can do any band 20 - 80m. I also have good reports on the **Tone/Parrett** phone TCVR. Steve G0FUV has also used a special 20m **Tone** variant for his latest Buildathon.

Meanwhile I have got the **Cam AM TX** under way which will eventually go with the new **Cary Regen TRF**. The new **Digital Signal Generator** will be available by the time you get this, 1.5 - 16 MHz on fundamentals and higher on harmonics, with crystal maker 'pips' down to 250 and 50 KHz. It goes extremely well with the new 3/5D counter (right). G3PCJ



Hot Iron is a quarterly subscription newsletter for members of the Construction Club. Membership costs £7 per year with the first issue for each year appearing in September. Those people joining later in the year will be sent the earlier issues for that year. Membership is open to all and articles or questions or comments or notes about any aspect of electronics—principally on amateur radio related topics— is very welcome. Notes on member's experience building their own gear, from kits or otherwise is most interesting to other constructors. To keep it interesting, your thoughts and ideas are required please! For membership, I only need your name and address and subscription. Send it or any other suggestions to Tim Walford, Walford Electronics, Upton Bridge Farm, Long Sutton, Langport, Somerset TA10 9NJ © G3PCJ

Editorial

Firstly - my apologies for being a bit late getting this issue of Hot Iron out. In truth I have been exceedingly busy with this darn computer writing up the radio aspects of the near-by wartime bunker, and latterly buying a new tractor. I would not have guessed how time consuming the latter might be! I contacted several dealers locally and was after a young second hand machine. Three did not bother to respond, 2 said they did not have anything that met the spec, one offered a slightly bigger machine than I wanted but, although made by a major manufacturer, it had several design features which were decidedly poor after-thoughts! One said wait two weeks till his rep was back, then nothing. The last offered a new machine that met the spec pretty well, had 3 yr warranty and came with low cost finance, at the same price as the only other second hand candidate! A no brainer - you can guess which continent it came from!

On more 'relevant' matters, the local radio clubs down here continue to flourish - I had the pleasure of talking to the Bristol RSGB Group recently. A good crowd turned up and from the questions etc afterwards, I knew they were thriving and interested in all sorts of different aspects of the hobby. Also a good mix of ages too which bodes well for the future! All Bristol's traffic lights were stuck at red on the way there but at least they had changed to green by the time I left! Tim G3PCJ

The Compton-Twofer by Steve Hartley G0FUW

For this year's QRP ARCI Pet Rock Sprint (3 hours of rock bound activity) I decided to put something on 20m. I happened to have been messing about with some simple crystal controlled transmitters and found the Twofer a nice compromise between complexity and output; 2W out from three junk box transistors, four if you count the keying transistor (see p129 of the RSGB book, International QRP Collection). Mine uses a BD139 for the PA, which is much cheaper than a 2N3866 or similar, and appears more tolerant of the odd shorted output socket, etc!

So what to use as a receiver? I had been having a tidy up in the shack and came across an old Walford Electronics 'Compton' receiver for 80m. I recalled it being quite a nice sounding receiver with a CW filter onboard. So, the band pass filter was changed to suit 20m and the 80m ceramic resonator was replaced with a 14.060MHz crystal and the conversion was complete. I now had TX and RX but how to link them?

I tried relay switching but the 'pop' in the headphones was just too loud. Tim suggested muting the AF amp, which was better, but there was still quite a 'pop' on return to receive. I decided to try electronic switching and borrowed a few bits from the Micro-mountaineer Revisited and a very pleasant delayed mute and sidetone was in place (see p2-10 in the ARRL book, More QRP Power).

My next quest was to have a single VXO to drive both RX & TX. That proved to be a step too far! I got close but the day before the contest the RIT was still not behaving so it was back to basics with two independent VXOs and a 'net' switch.

First try on air with the shack CobbWeb dipole brought a report of 579 from IV3ZJJ in Udine, which was encouraging.

Using my portable NorCal doublet and homebrew BLT tuner first contact in the contest was EA6UN on the Balearic Islands which boded well, but then the band closed and I had to QSY to 40m. Lots of effort for not many contest points? Well, being rock bound on TX & RX gains 5000 bonus points per band in the Pet Rock contest, so not too bad!

My 2011 resolution is to build a reliable VXO to drive both and provide RIT for next year's contest. I will report progress in due course (suggestions welcome!).

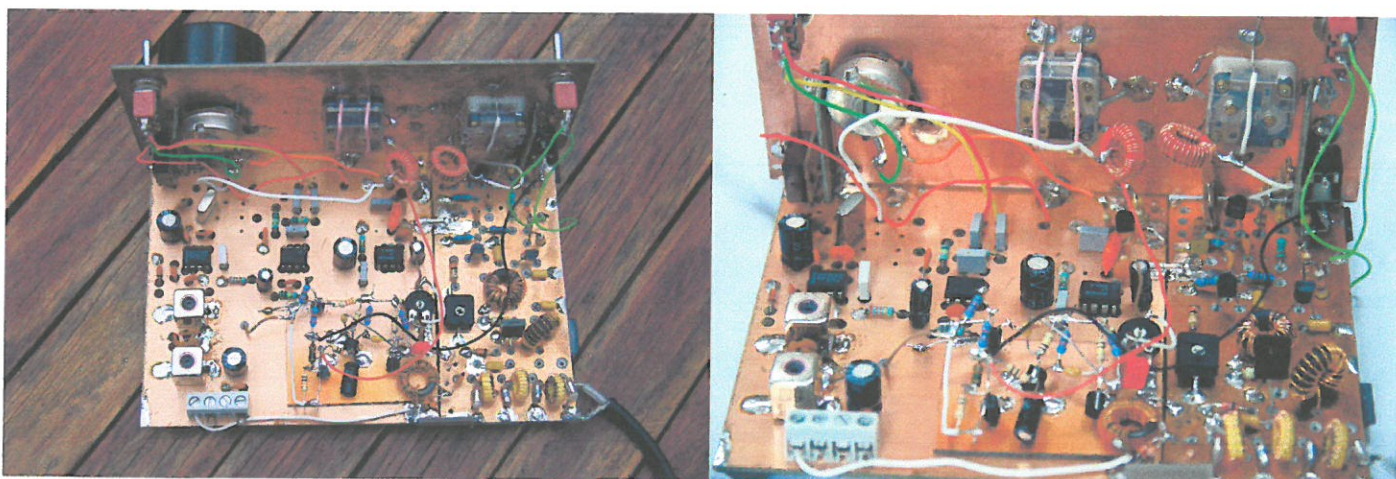

Comment by G3PCJ! I am delighted to see these pictures because this is just the sort of construction that I love! I am not sure the difference between these two pictures from Steve but they illustrate just how easy it is to alter things when partially built dead bug style. Printed circuit boards are a wonderful material for simple chassis construction and I have often built whole rigs without any etched tracks; everything supported by the ground connections and the supply rail decoupling capacitors.

Competition Time!

Here is a little challenge - who is the gentleman on the right? I am told he developed the Knack at a very early age and is seen here giving lessons in electronics to anybody willing to listen! In later years his shack has developed a very full array of test gear and other useful apparatus!



Rumour has it that feeding this antique heating appliance keeps him busy for much of the daylight hours and has also led to a delay in Government announcements about the renewable heat feed-in tariffs.

Entries on a post card to me by April 1st, when the winner will be picked by my wife and will receive a token gift! G3PCJ

Slow scan TV

These are thought to be the first pictures received by a Tone on 20m, courtesy Dave MOSXZ.



Ideal RX - Cary and Cam

Andrew Atkinson asked for some help in the last Hot Iron to achieve his ideal portable rig! I offered the comment that a regen TRF has the huge advantage that band changing is relatively easy due to the limited number of signals that have to be switched. It made me re-examine my regen TRF designs and see whether they could be improved - answer yes! I concluded that many serious operators don't like my very cheap flat form of construction, exemplified by the current Trull. I have decided to re-engineer it in the small upright format. I wish to keep something simple for very first time building youngsters, who will value the low end of the Medium Wave where Absolute Radio is still to be found as a very strong signal. So the **Cary** is a regenerative TRF which can do any one of 80m or 160m or MW in its simplest form (right). It retains audio output for a small L:S or phones, with an infinite impedance detector and an RF amp with adjustable gain. Changing to the small upright format allows space for a very tiny sounder as LS, with it all running off the on board PP3 9v battery.

Given the potential ease of band changing, I decided to add the holes/tracks for an optional 3 band version using the 3334 TOKO. This allows it now to do all three of 20, 40 or 80m! The hardest part was to obtain a reasonable tuning rate on each band without employing too many different capacitor values. Although I know what the values are because of the labelling on their bags, their markings are useless so have to be marked separately by me hence I don't want any more values than absolutely necessary! Out of interest I show the resonant circuits of the **Cary** right for this 3 band version.

The matching transmitter is the simple amplitude modulated **Cam** kit based on ceramic resonators - there are ones suitable for 80 and 160m with a bit of care! The actual frequency being adjusted with a trimmer when the net facility is employed. This afternoon I loaded them up into my 160m half-wave on 3615 KHz and was given good reports by stations in the Isle of Wight and South Wales. Relief! Below is the pair together and the AM RF output waveform. (A **Cam** is going to Bletchley for the RSGB's radio displays to demonstrate one type of modulation.) Special price for Con Club Members - £70 inclusive of P&P for both on 80m only! See website! G3PCJ

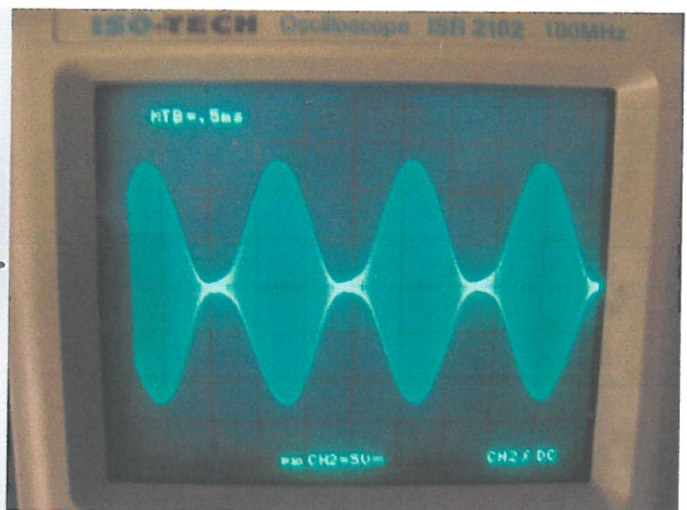
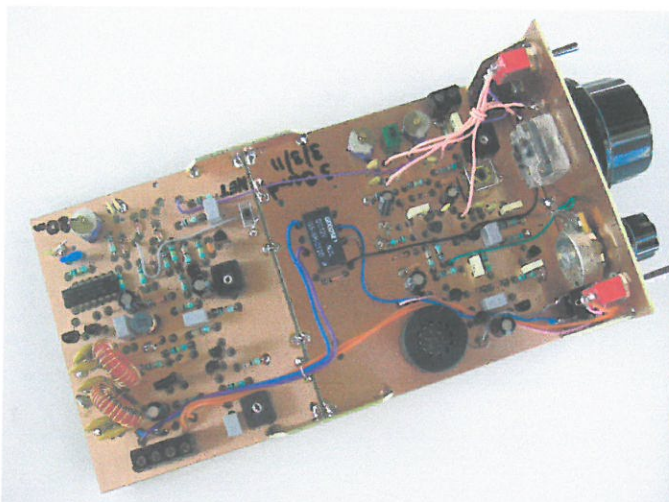
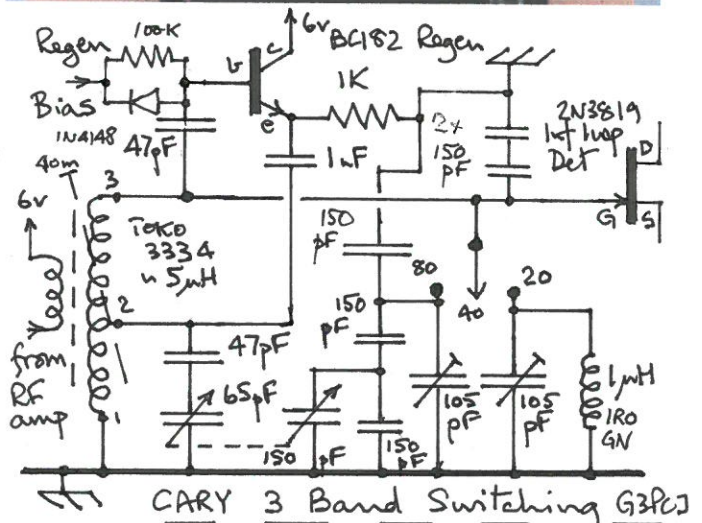
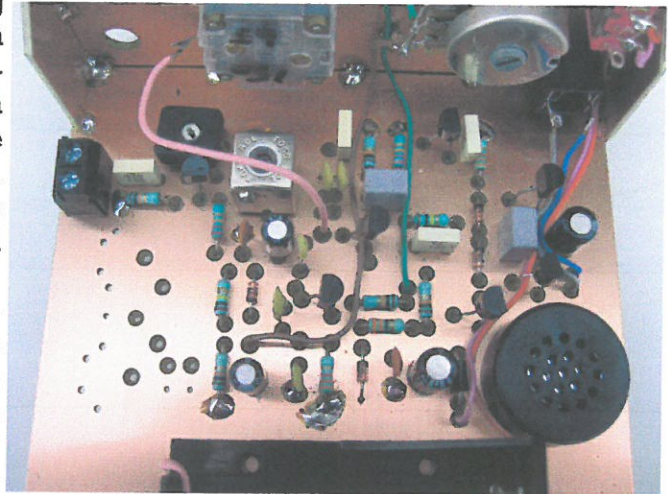

Digital Signal Generator

Last time I floated some ideas for a new digital signal generator which has developed into the kit shown on the first page. (This is not strictly true as the final version has two extra switches.) I have been pleasantly surprised by the stability of the main digital variable frequency oscillator which runs between about 6.5 to 16 MHz. The alternative main oscillator uses a crystal at 5 MHz for the receiver tuning calibration marker pips. Either oscillator can drive the dual bi-quinary dividers for variable fundamental outputs down to 1.5 MHz, or marker pips with a spacing of 250 or 50 KHz. Other switches are for power and the output level.

Adding a counter to this kit makes a really useful piece of test gear. I have arranged my own so that a further 3 way toggle can select the counter, a low impedance nominal 50R external source, or a 1M source and extra amplifier for use with a scope type probe. The photo right shows the front panel and the full 5 digit display - the normal 3 digit counter shows the KHz part of the frequency, and the Dig Sig Gen has space for the 2 extra MHz counting stages. If you are happy with the normal counter input sensitivity, and will not be using a scope probe, then an extra amplifier stage is not required. Its easy enough to add one, being only two transistors and I built mine dead-bug style on the back of the front panel (lower photo). The whole lot can run off the PP3 battery (or an external supply) so makes a very handy portable unit for setting up VFO's and rigs.

I have added a centre off toggle for output level selection; this is a bit of a compromise but it does have a low Z output with nominal levels of 200, 20 and 1mV p-p open circuit. For the variable frequency outputs, these are actually square waves and even the lowest would represent a strong signal at the input of a receiver! If the spike or 'pip' outputs are selected, although the last digital gate output has the same levels as above, the very narrow pulse spreads the energy over a much wider spectrum so that the actual level of any particular harmonic is very much lower. Input switching shown below. G3PCJ

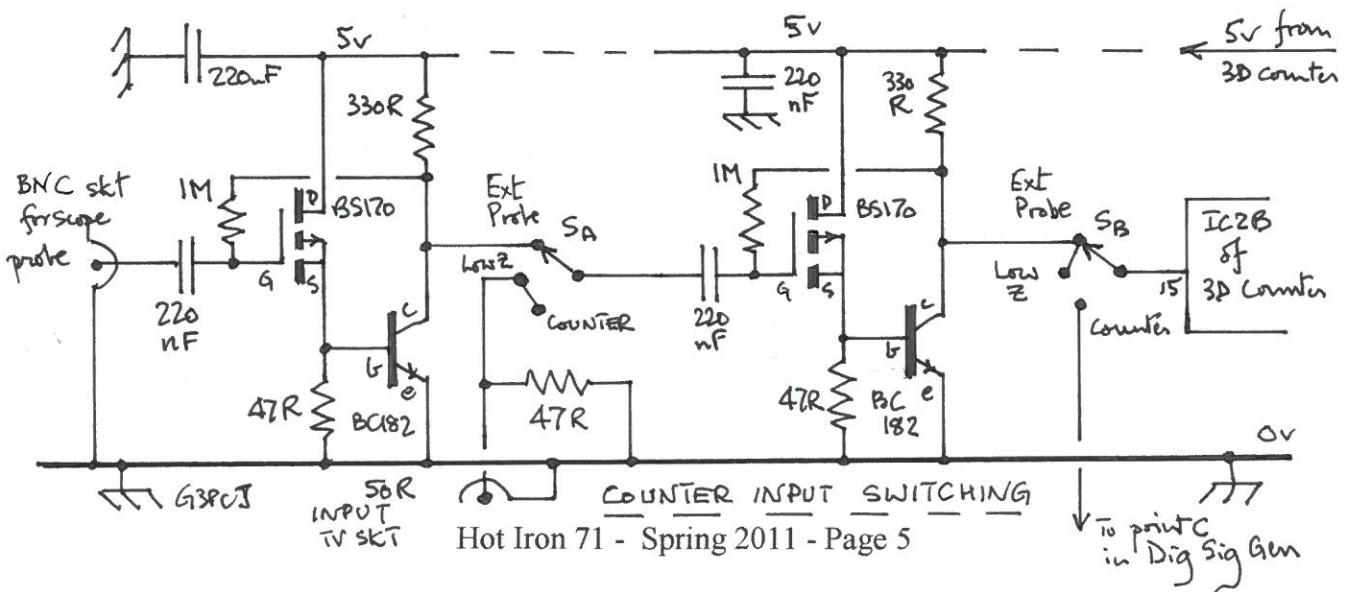
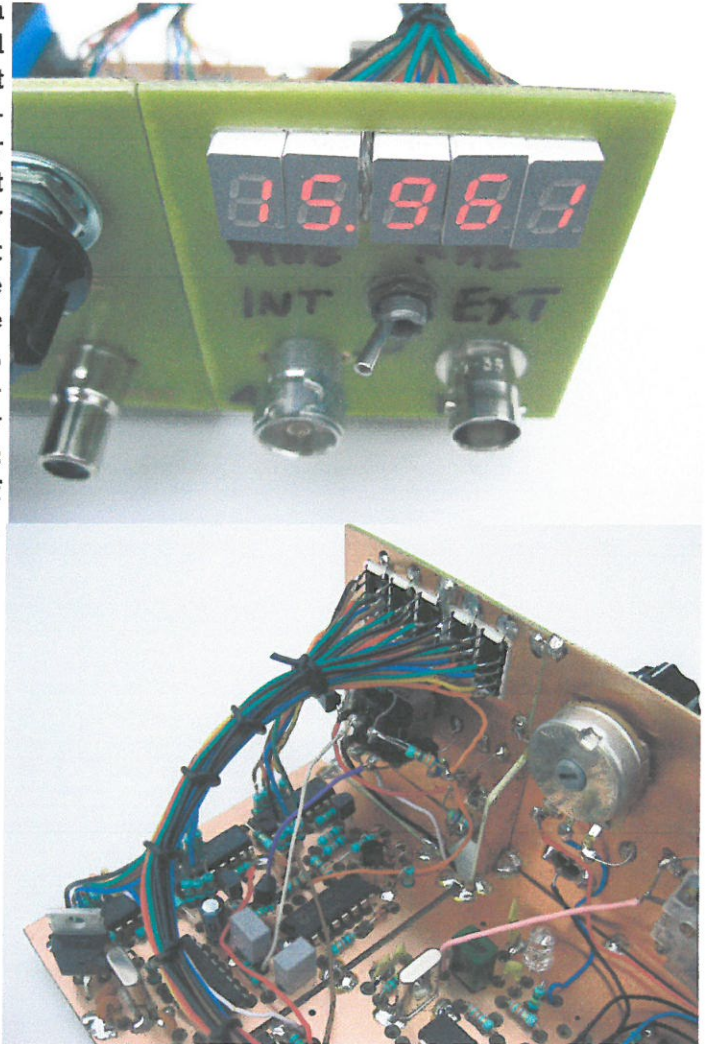

Fault finding!

One of my regular customers recently pointed out that my kit instructions are all about building the rigs, but are not so good at explaining how to repair them when they fail! It's a fair observation so here are some general notes about bringing a dead rig back to life! Obviously not all of these suggestions will be relevant in all cases so amend them as relevant! In nearly all cases, you will be stuck without the circuits ultimately.

I always start with a good physical examination! Broken wires, and or for my kits, missed topside ground solder points. This is still the most common fault despite strengthening the standard warnings about that! Giving it a good firm tap while held upside down often removes blobs of solder or swarf! Then look for burnt or broken tracks and any signs of dry solder joints. Often inexperienced builders do not use enough heat so that the solder forms round teardrops rather than smoother well tinned rounded curves! My experience with modern lead free solder is not great but it needs more heat than conventional 60:40 tin:lead solder. Do not be afraid of cooking electronic parts, modern ones are much more tolerant of heat than they used to be! It is much more likely that the PCB tracks will lift off the fibre-glass (or SRBP) board before any part gets damaged.

The next task is to apply power. Use an adjustable current limited and voltage regulated power supply. (I used to make these myself but in recent years they have become much cheaper and hardly worth the effort, especially as they often now include current and volt meters, so a commercially made one is a sound investment.) Set the voltage to the specified figure and then (assuming it does have over-current protection), set that to a little more than the anticipated load. Its not always easy to set the current turn off level but you should be OK to short the PSU output and then adjust the resulting current to the desired figure - try this with caution if you have not done it before! What do you set it for, if there is no guidance in the instructions or circuit? I would suggest about 100 mA for a simple RX, and perhaps 2-300 mA initially for a TCVR. If it has loads of relays, then this figure might need upping. And of course, when going to transmit, the draw might be very much higher than this - but most QRP type rigs will not draw more than an Amp or two at worst. Having connected and powered it up, wait for a little while and see if any smoke arises or if the current increases. If yes, this indicates that some stages is suffering thermal runaway and is most likely to be a power stage - audio or RF! Then check the internal supply rails are close to the nominal values. After this, one does really need to know the detail of the rig's circuits.

I find that the next easiest area to test are the rig's oscillators. Direct conversion rigs tend to have only one and you can often use a general coverage RX to listen around for it near to where it ought to be. Superhets will also have a carrier oscillator which should be very close to the nominal IF frequency. So far you don't need any fancy gear! But if you do need to set the frequencies, then a counter or the general coverage RX with digital readout are invaluable.

If the oscillators are working, then test the audio stages. If it's a RX, you should not need a special source - just yourself! Apply your finger to the shaft of a metallic screwdriver and dab this on to the audio signal path, starting at the output stage. If you get a click or a rough sounding hum, its likely to be working and will probably get louder as you advance towards the low level stages nearer the aerial. If you are working on a transmitter, you can listen to the speech amp stages with an external audio amplifier (with high Z input) turned well up initially.

After this you are into less easily tested stages like mixers and RF amplifiers. Having formed an opinion about the faulty area, it is always wise to measure the DC operating voltages with a high impedance voltmeter. Any transistor whose drain or collector is sitting at either 0 volts or the supply rail is suspicious until you have satisfied yourself that it should be like that! A transmitter output stage fed via a low value RF choke would be one of the few cases where the full supply volts on the drain/collector would be normal! But any at 0 volts indicates potential trouble (a shorted device!), but watch out for the open circuit device which might also make the supply volts appear on the drain/collector! If the bias voltages seem plausible try injecting RF signals into a RX from a sig gen; or for a TX, listen with the general coverage RX aerial near to individual stages.

It is most satisfying when you find the single dud joint in the rig that cost you £5! G3PCJ

Snippets!

Saturn on Vero Board?

Craig G0HDJ planned to build one of Richard Booth's Saturn RX using this form of construction and wondered if it would be OK for 40m. The answer is probably yes! Just in case, one needs to make certain the ground tracks are (very) low impedance - thick with multiple links so that they form some sort of rectangular grid. This will reduce the inductance and be far more effective than just thickening up a single long straight ground track with extra wires soldered on top. For a receiver it might not matter too much but it becomes much more important for a transmitter where the higher RF currents could escape into parts of the circuit that are a bit more sensitive. Although not usually a problem for a superhet like the Saturn, if TX currents get into a VFO operating at the same frequency (as in a DC rig), then it will cause chirp as the TX is keyed. 40m should be OK, and maybe even up to 10m but not low VHF with Vero board!

Unstable band switching

David Scrivens has just bought a 4 band Taunton that needs a little bit of TLC. It works fine on 40m but other bands seemed 'unstable' - I am not sure what he meant by this but I guessed that the signals (in/out/LO mixing) might not be consistent. The electronics are probably more reliable than the mechanics of the band relays. I suggested tapping the relays of the dodgy band to see what happens; once identified their lids can be prized off and the contacts lightly rubbed with brown paper to clean them. I suspect the relay contact material is not really suitable for such low signal level switching - break an Amp and they will self-clean, but not a fraction of a micro-Amp! I do know the single pole TR relays (no longer made) suffered this problem.

Lighting efficiencies

A recent note in Electronics Weekly suggested that plasma lighting energised by RF will provide greater efficiency and also last much longer, even compared to LEDs! The suggestion is to drive them with a few hundred MHz! Sounds like a potential serious transmitter to me! Their drawback seems to be the time required to get going.

Lighting technologies in comparison

| Type | Lifetime (hrs) | Luminous flux (klm) | Efficacy (lm/W) | Colour rendering | Colour temperature (K) | Start-up time (s) | Re-strike time (s) |
|--------------------------|----------------|---------------------|-----------------|------------------|------------------------|-------------------|--------------------|
| Incandescent | 2,000 | 1,700 | 10-17 | 100 | 3,200 | 0.1 | 0.1 |
| Fluorescent | 10,500 | 3,000 | 115 | 51-76 | 2,940-6,430 | 0.3 | 0.1 |
| LED | 25,000 | 130 | 60-100 | 30 | 6,000 | 0.1 | 0.1 |
| High intensity discharge | 20,000 | 25,000 | 65-115 | 40-94 | 4,000-5,400 | 60 | 480 |
| RF Plasma | 50,000 | 25,000 | 100-140 | 70-94 | 4,000-5,500 | 30 | 25 |

Squealing Mendips!

I am sad to report that this receiver has a minor annoying problem that I have failed to solve! When switched on, the audio filter stages squeak (or oscillate) for a short while until the DC bias conditions reach their normal levels. I cannot see any logical reason why abnormal DC levels should lead to this condition but it is clearly associated with the filter biasing. One approach that might help but is not a proper cure, would be to reduce the impedance level of the bias divider chain, so that the bias attains the normal level rather quicker - this would reduce the duration of the squeal. Reducing the values of R20 and R21 both by a factor of 10 should much reduce the duration but I am afraid it will not eliminate it. Much lower than this and the extra power consumption would be wasted really! My apologies to members with Mendips.

Digital Absorption Wavemeter

One inquirer suggested that an absorption wavemeter would be a good kit to add to the range, and might help to check his legality!! Unfortunately it such a simple circuit that I cant see it being a viable kit; and if it has to cover a large frequency range, the resonator switching gets messy! Also how to calibrate it? I soon realised that its another good application for the 3D counter. It needs a dual decade divider for XY.Z MHz - see below. G3PCJ

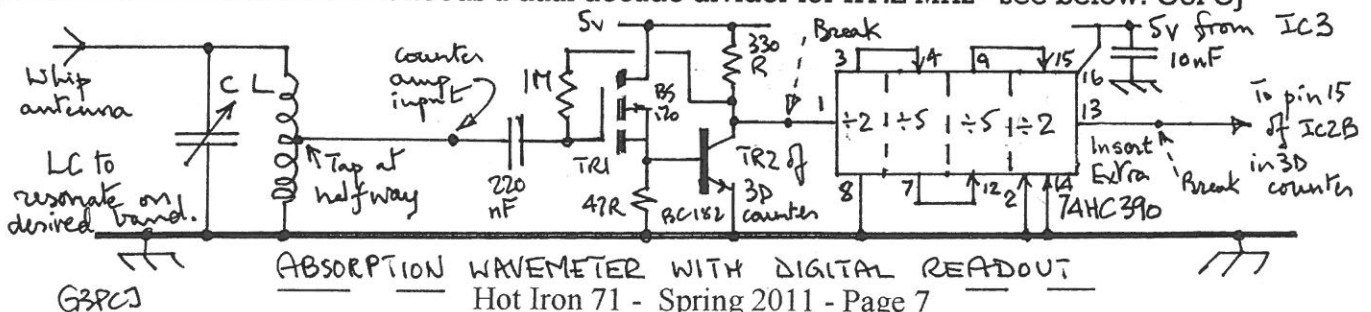

Yeovil QRP Convention

20th March 2011 at the Digby Hall, Sherborne, Dorset

Doors open 09:30 am to 4:00pm
Supported by the RSGB & RAFFA
Traders, Bring & Buy, Club Stalls
Contact Derek Bowden M0WOB email yarc-contact@tiscali.co.uk
Talks by Rob Micklewright G3MYM and Peter Chadwick G3RZP

I will be having a stall there. If you want any kits and are coming please let me know in advance so they can be prepared. Note the date is early this year!!



QRP in the Country 2011

I hope all of you living in Southern England already have the date in your diary! Just in case:-

July 17th 2011 at Upton Bridge Farm, Long Sutton, Somerset TA10 9NJ

I am working on several new attractions and will be welcoming several radio personalities including Rob Mannion G3XFD, Editor of Practical Wireless, and Rev George Dobbs G3RJV, Editor of Sprat. Please do encourage your local Club to come along with any sort of radio related stand that explains some of its activities and which will be of interest to others. No charges! Just send me an e mail to walfor@globalnet.co.uk

Keep your fingers crossed for good weather - if necessary we will move into the cattle sheds!



Snippets!

Saturn on Vero Board?

Craig G0HDJ planned to build one of Richard Booth's Saturn RX using this form of construction and wondered if it would be OK for 40m. The answer is probably yes! Just in case, one needs to make certain the ground tracks are (very) low impedance - thick with multiple links so that they form some sort of rectangular grid. This will reduce the inductance and be far more effective than just thickening up a single long straight ground track with extra wires soldered on top. For a receiver it might not matter too much but it becomes much more important for a transmitter where the higher RF currents could escape into parts of the circuit that are a bit more sensitive. Although not usually a problem for a superhet like the Saturn, if TX currents get into a VFO operating at the same frequency (as in a DC rig), then it will cause chirp as the TX is keyed. 40m should be OK, and maybe even up to 10m but not low VHF with Vero board!

Unstable band switching

David Scrivens has just bought a 4 band Taunton that needs a little bit of TLC. It works fine on 40m but other bands seemed 'unstable' - I am not sure what he meant by this but I guessed that the signals (in/out/LO mixing) might not be consistent. The electronics are probably more reliable than the mechanics of the band relays. I suggested tapping the relays of the dodgy band to see what happens; once identified their lids can be prized off and the contacts lightly rubbed with brown paper to clean them. I suspect the relay contact material is not really suitable for such low signal level switching - break an Amp and they will self-clean, but not a fraction of a micro-Amp! I do know the single pole TR relays (no longer made) suffered this problem.

Lighting efficiencies

A recent note in Electronics Weekly suggested that plasma lighting energised by RF will provide greater efficiency and also last much longer, even compared to LEDs! The suggestion is to drive them with a few hundred MHz! Sounds like a potential serious transmitter to me! Their drawback seems to be the time required to get going.

Lighting technologies in comparison

| Type | Lifetime (hrs) | Luminous flux (klm) | Efficacy (lm/W) | Colour rendering | Colour temperature (K) | Start-up time (s) | Re-strike time (s) |
|---------------------|----------------|---------------------|-----------------|------------------|------------------------|-------------------|--------------------|
| Incandescent | 2,000 | 1,700 | 10-17 | 100 | 3,200 | 0.1 | 0.1 |
| Fluorescent | 10,500 | 3,000 | 115 | 51-76 | 2,940-6,430 | 0.3 | 0.1 |
| LED | 25,000 | 130 | 60-100 | 30 | 6,000 | 0.1 | 0.1 |
| Intensity discharge | 20,000 | 25,000 | 65-115 | 40-94 | 4,000-5,400 | 60 | 480 |
| Plasma | 50,000 | 25,000 | 100-140 | 70-94 | 4,000-5,500 | 30 | 25 |

Squealing Mendips! I am sad to report that this receiver has a minor annoying problem that I have failed to solve! When switched on, the audio filter stages squeak (or oscillate) for a short while until the DC bias conditions reach their normal levels. I cannot see any logical reason why abnormal DC levels should lead to this condition but it is clearly associated with the filter biasing. One approach that might help but is not a proper cure, would be to reduce the impedance level of the bias divider chain, so that the bias attains the normal level rather quicker - this would reduce the duration of the squeal. Reducing the values of R20 and R21 both by a factor of 10 should much reduce the duration but I am afraid it will not eliminate it. Much lower than this and the extra power consumption would be wasted really! My apologies to members with Mendips.

Digital Absorption Wavemeter

One inquirer suggested that an absorption wavemeter would be a good kit to add to the range, and might help to check his legality!! Unfortunately it such a simple circuit that I cant see it being a viable kit; and if it has to cover a large frequency range, the resonator switching gets messy! Also how to calibrate it? I soon realised that its another good application for the 3D counter. It needs a dual decade divider for XY.Z MHz - see below. G3PCJ

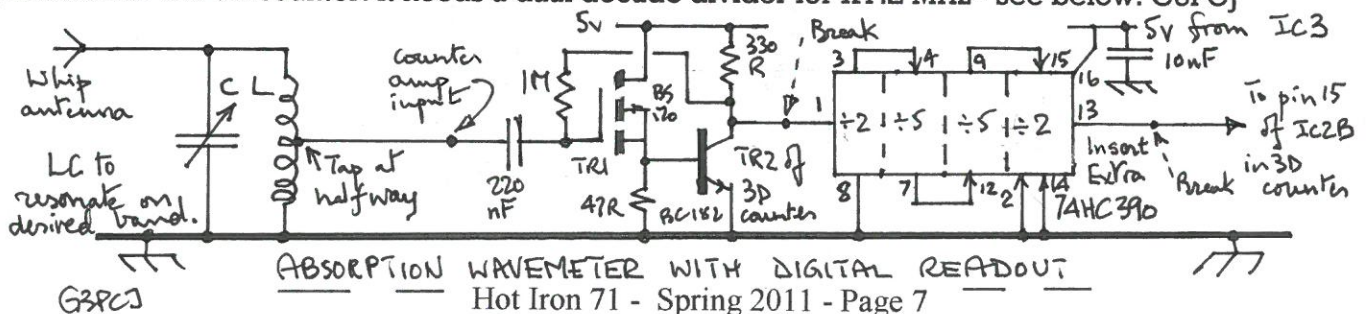

Snippets!

Saturn on Vero Board? Craig G0HDJ planned to build one of Richard Booth's Saturn RX using this form of construction and wondered if it would be OK for 40m. The answer is probably yes! Just in case, one needs to make certain the ground tracks are (very) low impedance - thick with multiple links so that they form some sort of rectangular grid. This will reduce the inductance and be far more effective than just thickening up a single long straight ground track with extra wires soldered on top. For a receiver it might not matter too much but it becomes much more important for a transmitter where the higher RF currents could escape into parts of the circuit that are a bit more sensitive. Although not usually a problem for a superhet like the Saturn, if TX currents get into a VFO operating at the same frequency (as in a DC rig), then it will cause chirp as the TX is keyed. 40m should be OK, and maybe even up to 10m but not low VHF with Vero board!

Unstable band switching David Scrivens has just bought a 4 band Taunton that needs a little bit of TLC. It works fine on 40m but other bands seemed 'unstable' - I am not sure what he meant by this but I guessed that the signals (in/out/LO mixing) might not be consistent. The electronics are probably more reliable than the mechanics of the band relays. I suggested tapping the relays of the dodgy band to see what happens; once identified their lids can be prized off and the contacts lightly rubbed with brown paper to clean them. I suspect the relay contact material is not really suitable for such low signal level switching - break an Amp and they will self-clean, but not a fraction of a micro-Amp! I do know the single pole TR relays (no longer made) suffered this problem.

Lighting efficiencies A recent note in Electronics Weekly suggested that plasma lighting energised by RF will provide greater efficiency and also last much longer, even compared to LEDs! The suggestion is to drive them with a few hundred MHz! Sounds like a potential serious transmitter to me! Their drawback seems to be the time required to get going.

Lighting technologies in comparison

| Type | Lifetime (hrs) | Luminous flux (kdm) | Efficacy (lm/W) | Colour rendering | Colour temperature (K) | Start-up time (s) | Re-strike time (s) |
|--------------------------|----------------|---------------------|-----------------|------------------|------------------------|-------------------|--------------------|
| Incandescent | 2,000 | 1,700 | 10-17 | 100 | 3,200 | 0.1 | 0.1 |
| Fluorescent | 10,500 | 3,000 | 115 | 51-76 | 2,940-6,430 | 0.3 | 0.1 |
| LED | 25,000 | 130 | 60-100 | 30 | 6,000 | 0.1 | 0.1 |
| High intensity discharge | 20,000 | 25,000 | 65-115 | 40-94 | 4,000-5,400 | 60 | 480 |
| RF Plasma | 50,000 | 25,000 | 100-140 | 70-94 | 4,000-5,500 | 30 | 25 |

Squealing Mendips! I am sad to report that this receiver has a minor annoying problem that I have failed to solve! When switched on, the audio filter stages squeak (or oscillate) for a short while until the DC bias conditions reach their normal levels. I cannot see any logical reason why abnormal DC levels should lead to this condition but it is clearly associated with the filter biasing. One approach that might help but is not a proper cure, would be to reduce the impedance level of the bias divider chain, so that the bias attains the normal level rather quicker - this would reduce the duration of the squeal. Reducing the values of R20 and R21 both by a factor of 10 should much reduce the duration but I am afraid it will not eliminate it. Much lower than this and the extra power consumption would be wasted really! My apologies to members with Mendips.

Digital Absorption Wavemeter One inquirer suggested that an absorption wavemeter would be a good kit to add to the range, and might help to check his legality!! Unfortunately it such a simple circuit that I cant see it being a viable kit; and if it has to cover a large frequency range, the resonator switching gets messy! Also how to calibrate it? I soon realised that its another good application for the 3D counter. It needs a dual decade divider for XY.Z MHz - see below. G3PCJ

