

Hot Iron

Spring 2010
Issue 67

Contents

Simple VHF antenna
The Digit
Switch Mode PSU
configurations
Regens into
super-regens?
Low value capacitors
Snippets
Laptop Batteries
Any old items?
QRP in the Country!

The Walford Electronics web-
site is also at
www.walfordelectronics.co.uk

Kit Developments

The Mendip and Polden are being tested by Eric Bowell and Richard Booth. This has thrown up a few small errors in the instructions but no significant problems with the circuit or track! By the time you read this I shall be ready to take orders at £110 post paid. (In case you have forgotten, it's a specialist 3 band 20/40/80m 5W CW TCVR with phasing RX - see website.)

The other new projects are the **Digit** scanning counter (see later) and the Tone/Parrett combination (right). This pair are an entry level 80m single sideband receiver and separate 1.5W SSB TX which together form a TCVR, & can take the 10W Linear. I need some early builders! Tim

Editorial

How time flies! I must apologise for being a little late in production of this issue of Hot Iron. Its been a long and cold winter down in Somerset so I have spent quite a bit of time on farm and electronic paperwork in the house! The result is some new projects (see later) that were so engrossing that I have hardly noticed that we are now in another month! However the good news is that it is at last beginning to dry up and the sun has been out leading to a more positive attitude on many fronts! Soon I shall have to start thinking about how to erect some extra aerials for QRP in the Country. There is plenty of space but too few sky hooks! For these occasions, where multi-band operation is wanted, my good friend Eric Godfrey G3GC, used always to say that there is nothing to beat a half wave for 160m, supported at the middle and ideally at the ends also; fed by open wire line with a good balanced resonant AMU. I recall him spending hours making such a feed line with glass spacers and hard drawn copper wire; but I shall be resorting to BT style twin 'drop wire' which can be split for the arms!

I mentioned the price of mechanical items last time - imagine my surprise when I contemplated re-ordering the upright heatsinks that I use for the 5W rigs. My usual distributor had upped the price to nearly £4 each! That called for some hard bargaining!
Tim G3PCJ

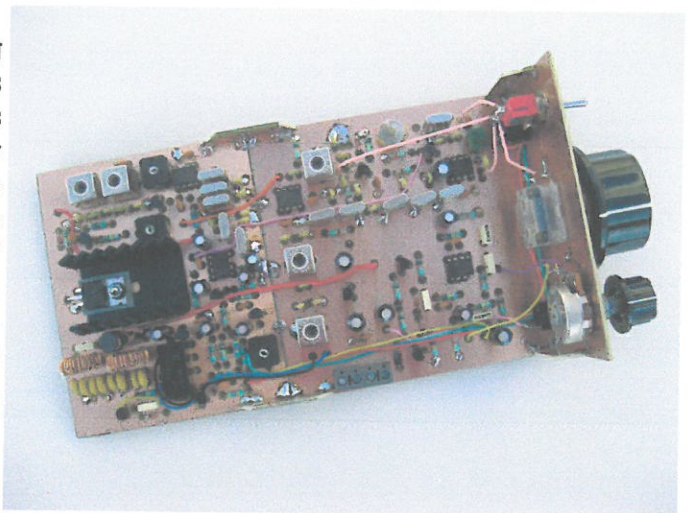

Hot Iron is a quarterly subscription newsletter for members of the Construction Club. Membership costs £7 per year with the first issue for each year appearing in September. Those people joining later in the year will be sent the earlier issues for that year. Membership is open to all and articles or questions or comments or notes about any aspect of electronics—principally on amateur radio related topics—is very welcome. Notes on member's experience building their own gear, from kits or otherwise is most interesting to other constructors. To keep it interesting, your thoughts and ideas are required please! For membership, I only need your name and address and subscription. Send it or any other suggestions to Tim Walford, Walford Electronics, Upton Bridge Farm, Long Sutton, Langport, Somerset TA10 9NJ © G3PCJ

Simple antennas for Low VHF by Andy Howgate

Some years ago I made several J pole antennas; they are a super antenna and work ever so well. It is made from plumbers copper pipe so it takes some time to make one, and mounting it is not so easy because you have to make up an insulating section and the engineering takes a hell of a lot of effort. I searched the web for something simple and found a few ideas on the DX zone website - how some chap got his 4m antenna working I will never know because I tried it without any success! Eventually I settled on an idea I have used time and again over the years, either in wire form for horizontal or a more sturdy fixed structure for vertical polarisation - but always its the hardware and making the antenna fit to some location that is the problem.

I had a very aged 2m/70cm Colinea so that came apart and the inner radiator, which is inside the glass fibre tube, was removed and in its place I used one of those pull up whips (a long one) used on some VHF BC radios. I had a pair of them which was handy - the whip is fully adjustable from 6 inches to 1.2m so I set it for 101.5 cms which is a 1/4 wave right in the middle of the 4 m band. For the element lengths, I find if one uses the usual formula for an HF dipole it is not far out for VHF up to 2m. Even if the match is not good immediately, you can play with the angles till it come right.

I put the antenna back together and then used the other pull up whip as the counterpoise or other half of a dipole; but the difference is to get a perfect match this is angled at about 100 degrees from the vertical radiator - this gives a 50R match from previous experience; if it were arranged as a normal vertical dipole the match would be nearer 70R and thus offer an SWR a little way off - its probably OK but angling the ground side element so it looks like a drooping L shape, you can get a full flat match - I suppose its a bit like a 3 radial ground plane with two ground planes missing however I have found this makes an excellent antenna.

Now you would think this vertical will be OK till you bolt it to another structure like a pole but oddly adding much metal to the antenna does not affect it at all; it appears to be the dipole radiator length set at an angle that has the affect on bringing the antenna to a match. Satisfied with my efforts once it was up, I rechecked the match and it is flat across the whole of the 4m band. Great! So put out a call on 70.450 FM, and low and behold I worked a station up the coast from here - some 28 miles with 4 watts so I reckon that was darned good with the antenna only 20ft off the deck, so at no great height, the other station was using 15 watts.

You can use the same approach of altering the line up of the two elements for a nominally horizontal VHF antenna. My 6m dipole is like this but with less than 180 degrees between the arms so it resembles a shallow V dipole, but set nominally horizontal for SSB working - again one can get an excellent match.

Like I said - a simple antenna, without major matching networks and hours of engineering!

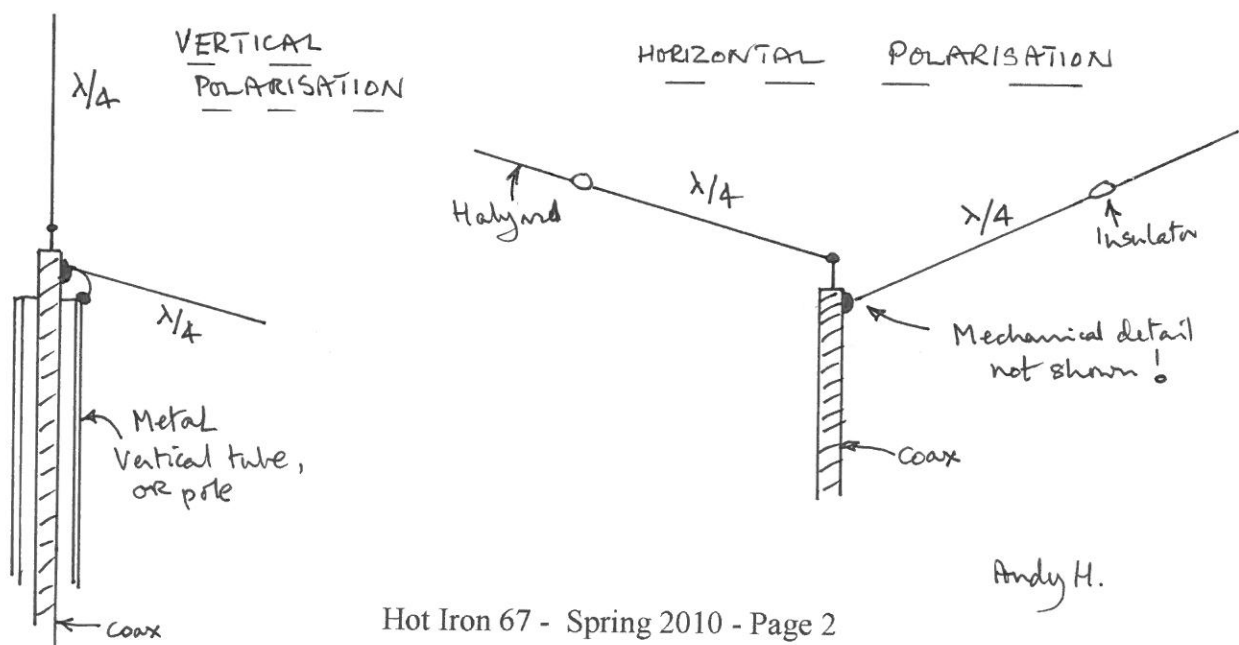

The Digit

The counter was given this strange name by Andy Howgate when we were discussing an earlier version! The intention is to reduce the cost (and ease of wiring to the display) by sequentially scanning and showing the numbers to be displayed on a single 7 segment display. This cuts down the number of wires to the display to just nine; and this new design allows the display to be mounted on the counter PCB, or for that end to be cut off and connected by a ribbon cable.

The challenge was to find a discrete logic approach that builders would be able to understand, would permit construction and testing in stages, and which could be repaired in the event of failures! (Undoubtedly a micro-processor approach would have less parts and be cheaper, but the designer is then the only person who understands how it and the software works, and its unlikely to be repairable - so no good for us!) CMOS decade up/down counters are needed to minimise the supply current and electrical noise. The 74HC192 is suitable and can be cascaded directly for use up to over 40 MHz. By using an accurate 1 mS duration for its counting period, the least significant counter stage will then show the KHz number so that five stages will allow a maximum reading of 99.999 KHz (not actually achievable due to the chip max frequency limit.) Each chip has a four bit digital output for its decimal count number; so these five 4 bit numbers have to be sequentially input to a suitable driver chip that will also decode the display segments to be activated. I choose a large 7 segment LED because it is far cheaper than any liquid crystal display! This leads to the simplified block diagram right.

The reading of the counter outputs sequentially leads to a quite complex gating task, which if it were to be done with integrated circuits, would add many more chips; luckily it can be done with diodes as there is no requirement for high speed! Each 4 bit count number has to be first ANDed with the particular display digit period signal, and then ORed onto the four display driver input lines. This (simple!) logical task needs 40 diodes and 24 resistors so is relatively very cheap! The partial circuit right shows how it is done when speed is not an issue, by increasing the resistance values of successive stages to avoid loading the earlier one.

One other trick is to alter the control of a 74HC4060 clock divider so that it provides accurate 1 mS pulses repeating about every 0.2 seconds for timing and sequencing the displayed number! Add in the two input channels for up or down counting so that it can suit additive or subtractive superhets, or rigs with converters like the Mendip, with either input up to about 45 MHz and one has a very versatile low cost unit. Just £24 & some care! G3PCJ

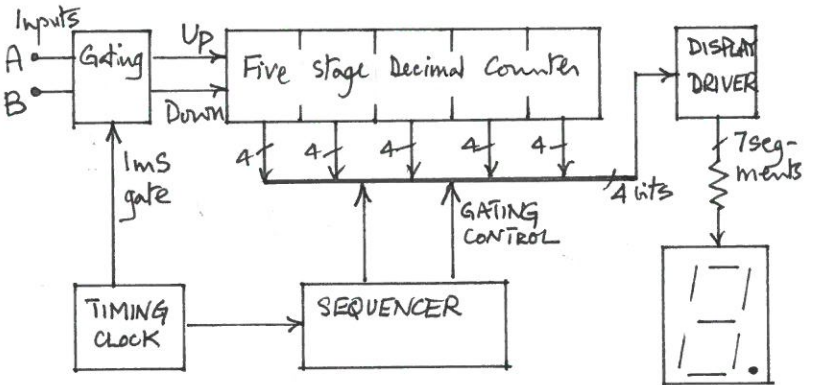

BLOCK DIAGRAM OF THE DIGIT

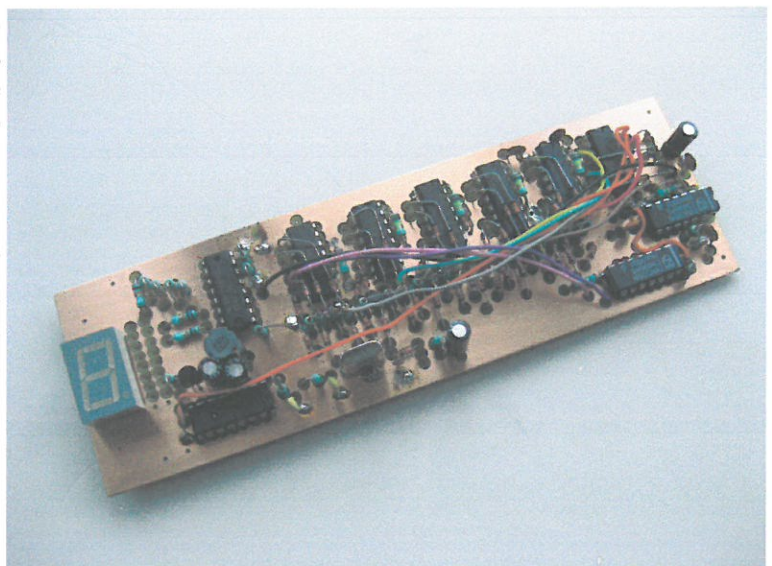
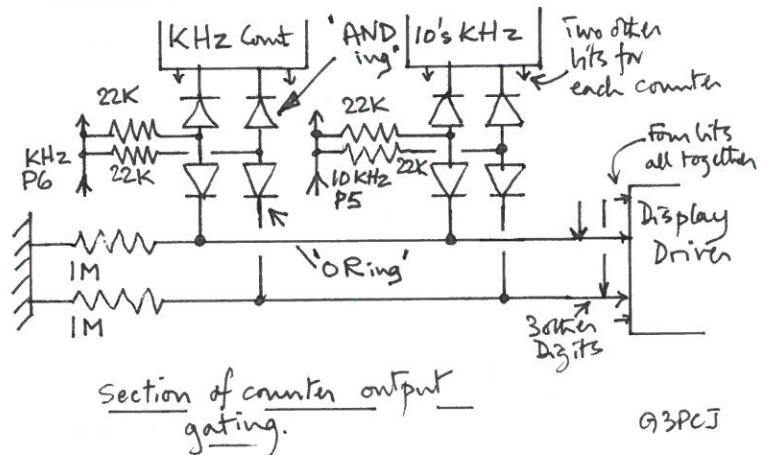

Switched Mode PSU Configurations

I have always been intrigued by the different topologies that are used in modern switch mode PSUs - there are many whose merits for different applications I have never properly understood! Because they have a reputation for being electrically noisy, I have always stuck with (wasteful) linear regulators within my rigs. However, with the increasing emphasis on design for reduced power consumption in modern commercial electronics, you cannot ignore the advantages which come from using switching technology. In addition, with decades of experience, the methods to tame the electrical noise problem are now also better understood. The diagrams down the right show five of the more common approaches with some brief comments on their uses.

Buck. Step down. Typically V_{in} is 3 to 5 times V_{out} . Up to 5A. Good efficiency.

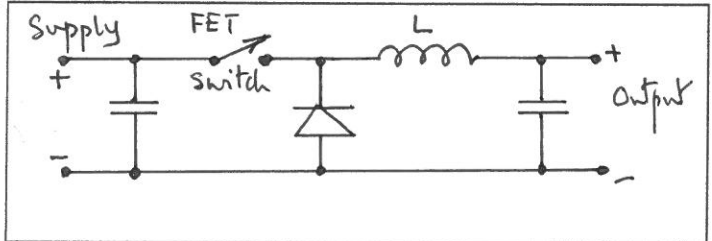

Synchronous Buck. Step Down. V_{out} nearer V_{in} . Better efficiency under high output over 5A.

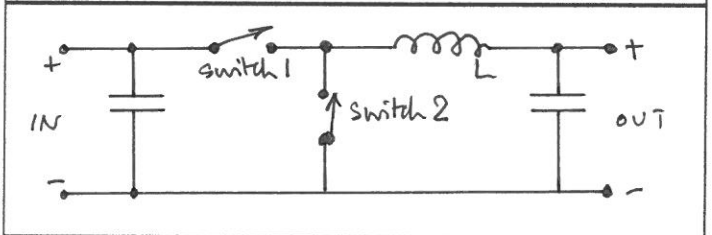

Boost. Step up. Transformerless design suitable for more than 200 mA up to about 20W and output less than 7 times input voltage.

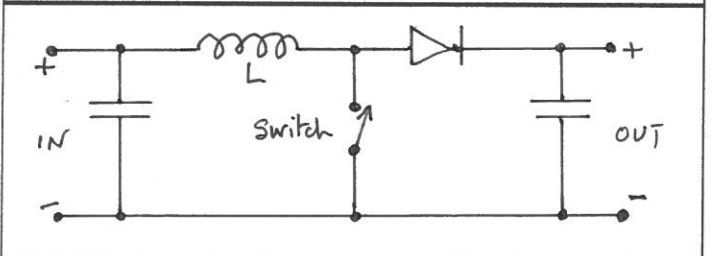

Flyback. Step up or down due to transformer which also gives isolation and potentially many voltage lines of either polarity. Suits higher output voltage ratio than Boost configuration. To 100W. Can use higher switching frequency than raw AC mains hence small transformer.

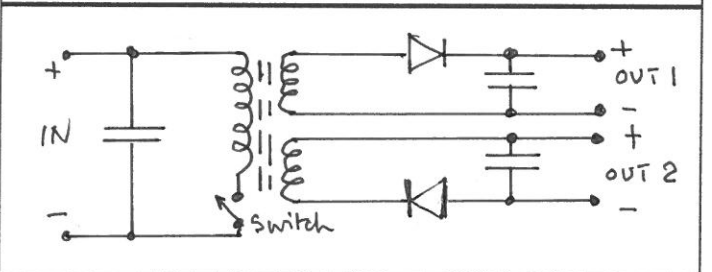

CUK Can invert for negative V_{out} with positive V_{in} without a transformer.

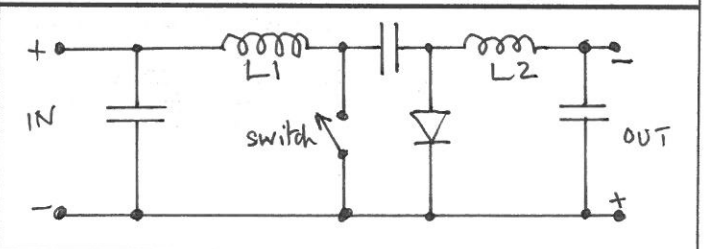

Comment! I see that one manufacturer advocates a combination of Buck and Boost (right) for automobiles where V_{out} is say 5 volts but under cold cranking the battery input may be down to nearer 4 volts instead of normal 13.8v! In practice the switches are mostly watty FETs driven hard on or off with much thought about the actual current paths to reduce radiation (avoid loops) and plenty of decoupling for noise reduction. G3PCJ

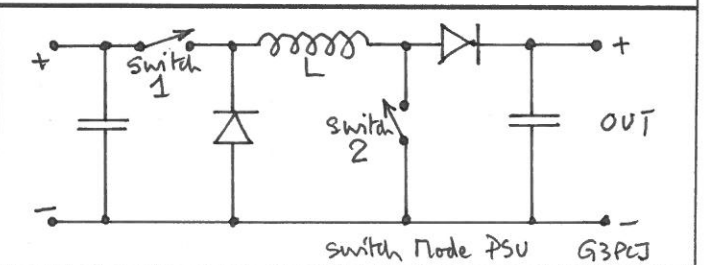

Regens into Super-Regens?

I have been asked recently if the Chirnside, which is normally a plain regen, can be turned into a super-regen RX. This answer is yes and no! Yes, it can but then its unlikely to be all that good for modern amateur use! First a word of explanation! The characteristic of a regen that makes it so appealing is that it greatly increases the tuned circuits Q when near the onset of oscillation - this has two desirable consequences. Firstly the RF bandwidth goes down increasing the selectivity markedly and this leads also to a big increase in gain. The bandwidth can get so small (for HF circuits) that it will cause clipping of the sidebands and so reduce the received audio bandwidth of conventional AM (and also of DSB/SSB). Hence it has much merit in a crowded band! The box right shows the RF part a typical plain regen. Note that I add a diode compared to many designers because this will stabilise the oscillation amplitude for those conditions when oscillation is required (CW and SSB/DSB). The oscillatory circuit can be a Colpitts (as shown) or the Hartley configuration, but the former has more discrete capacitance which helps to swamp changes in device capacitance with bias voltage and temperature.

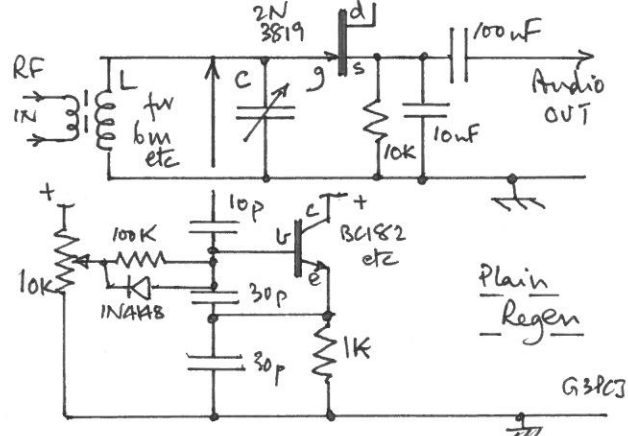

For the super-regen, the oscillations are allowed to build up and then killed off on a regular basis which is called quenching. This can be self controlled or directed by an external quenching oscillator whose output is applied to the regen's bias input. For my experiments about wartime super-regens, I wanted external control of the quenching frequency and bias changes. I modified a 6m Chirnside circuit as shown below so that it could in effect be either. When detector output is viewed with a scope triggered of the quenching oscillator, it is lovely to see the effect that introducing an RF signal has! The normal detector output is the pulse envelope of the build up of the regen's RF signal. In my case I let this RF envelope hit a bias limit so that it was the *earlier* rising edge of the envelope that indicated the presence of the incoming RF signal. Without any RF input, the envelope peaked about 5 μ s after the bias change, and the introduction of the RF carrier (from a GDO on the next bench set to 50 MHz) made that rising edge occur about 1 μ s earlier. It is this change in timing (and hence area of the pulse envelope) which can be used to demodulate the audio modulation of the incoming conventional AM signal.

The consequence of making the 'detector' super-regenerative is that it becomes a sampled data system where Mr Shannon's famous sampling theorem comes into play. He pointed out that to recreate a signal, the sampling rate had to be at least twice the inverse of the signal's bandwidth. A consequence of this is that the RF bandwidth of the regen circuit is now affected by the frequency at which it is quenched. A low quenching rate will lead to less change in bandwidth and vice-versa. It is however inevitable that the RF bandwidth is appreciably greater than for the plain regen. It's a complex relationship and because the quenching rate needs to be super-sonic, the bandwidth increase is significant. This means that for a crowded modern band with large signals, the receiver is likely to be swamped and unable to distinguish one signal from another. Because these conditions did not apply in the 1940s as there were so few signals, the advantage of extremely high gain was far more important than the loss of selectivity. In fact the wider bandwidth was actually required on reception to ignore the jump in RF frequency when the other set went to transmit. (These sets often used a single RF circuit to determine the frequency for reception and transmission.)

Hence it is best to alter a regen to super-regen with care so that it can be either! Tim G3PCJ

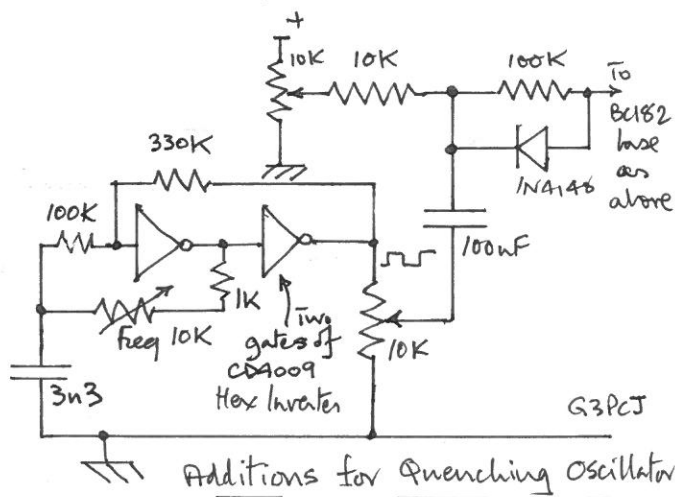

Low Value Capacitors

Recently I realised my stock of 150 pF ceramic plate capacitors was uncomfortably low and I went to order some more. Imagine my annoyance when I found that none of Farnell, RS, Rapid, Maplin or CPC had any of them! These are the small rectangular thin yellow jobs with almost indecipherable markings! It eventually emerged that they are no longer made - I suspect it has something to do with the fire in the factory that the manufacturer BCE-Sud had about 2 years ago!

This is really rather worrisome as negative temperature coefficient capacitors are needed for VFO circuits to counter the positive tempco which most inductors exhibit - including most of the (no longer made) TOKOs that are commonly seen in home built amateur HF equipment! Without these negative tempco compensating capacitors the VFO will be unstable; the inductance increases in value as it warms up, and hence the frequency of the VFO goes down. The yellow 150 pF ceramic plate caps had a N150 tempco meaning that their value decreased by 150 parts per million for each degree Celcius rise in temperature to compensate for the change in inductance.

For 18 pF and below, the yellow ceramic plate range had a tempco of zero +/- 30 ppm/°C, for 22 pF to 150 pF it was -150 +/- 30 ppm/°C and over 150 pF it was -750 +/- 120 ppm/°C. Hence anything larger than 150 pF was useless for VFO purposes as the compensation was too great. Many years ago similar capacitors were made with a grey body and had a coloured flash to indicate the tempco, black for the nominal zero tempco - this is also known as COG or NPO - the latter meaning negative positive zero! The N150 type had an orange flash and the N750 was purple.

I have failed to find any source of a complete range of N150 types but I did eventually find that some values of the yellow type were still in stock and I have bought quite a lot of them, but there are gaps in my inventory. Sorting through my old stocks I found that I did have quite a lot of 150 pF with the desired orange N150 flash (see right) made by other manufacturers and I shall supply these only where they are used for VFOs. For general use in tuned circuits such as RX input filters then it is not necessary to have the N150 types and I will supply COG or NPO versions. So for all future kits, I shall identify the ones that need to be temperature compensating types! It's a complication that I would prefer to avoid but we will

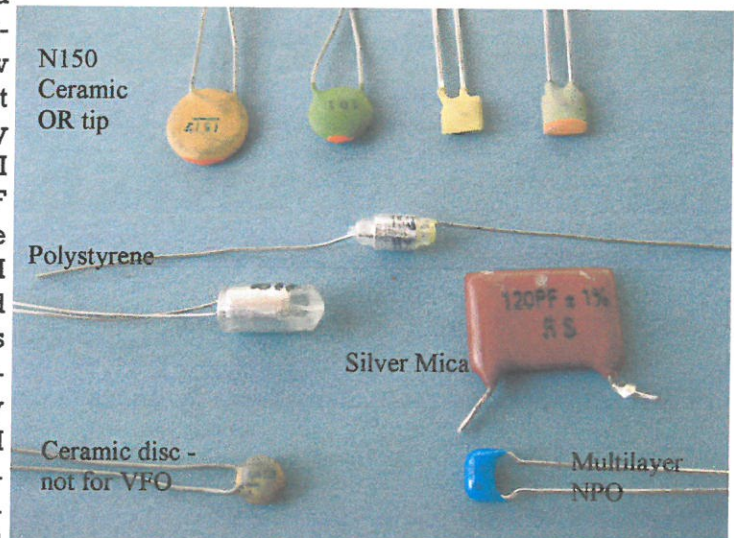

have to live with it! I guess the reason that none are made any more is that nobody makes HF VFOs commercially any more - they use microprocessor controlled DDS chips instead! By the way, those round yellow 65 pF film trimmers that I use are also no longer made!

The good news is that COG or NPO ceramic disc types with values suitable for tuned circuits are available but beware - their tolerance is often +/- 5 or even +/- 10% compared to the +/- 2% of the yellow ceramic plate types. We shall have to get used to using these instead!

You can also still buy silver mica low value caps (usually small positive tempco but wide variation); they are expensive often starting at nearly £1 (for small quantities) for small values and rising to £20 for 47 nF!! You can also still get the small cylindrical polystyrene variety (usually N150) but the value range is often limited and they start at about £1.25 each 1 off!

As an aside, do not use types radial multi layer types with X7R or Y5V dielectrics for tuned circuits. The former has a tolerance of +/- 10% but a tempco of +/- 20%. The Y5V sort has a tolerance of -20 or +80% and tempco of +22% or -82%. Both of these sorts can be used for decoupling supplies but they can be micro-phonic, so are not good as coupling capacitors in audio applications. It is better to stick with polyester for audio work, or ordinary aluminium electrolytics. I am afraid the supply of nearly all through PCB components is getting distinctly awkward! Tim G3PCJ

Snippets!

Very High Speed! Toshiba have recently announced the ability in their silicon foundries to offer 180 GHz RF devices using 40 nm CMOS. These devices can be integrated with other circuits on their 'system-in-package' devices. The f_t of these transistors can be 90, 140 or 180 GHz! Makes the BC182 @ below 300 MHz look a bit slow! Passive elements both capacitive and resistive can be added, as well as varactors and half turn differential or symmetrical inductors. Many of these parts have zero tempco! (What a relief - see previous page!) All you need to do is send them a net-list and Spice models etc and away you go!

Standards I came across this diagram right showing the bandwidth and frequency of various radio services recently. I must admit to being puzzled as to how many of the modern 'digital' formats are supposed to use less bandwidth than the earlier versions. (What happened to Mr Shannon's opinion?) I suppose that the digital encoding can be more efficient (so reducing the bandwidth required) but the

increase in data content brings the bandwidth numbers back up again. I am struck strongly by the increase in power consumption of many domestic receivers that is required to decode these modern formats compared to plain conventional AM or FM. This cannot be good for the environment - especially in the less developed parts of the world where simplicity, repairability and long life are more important than in so called advanced western societies.

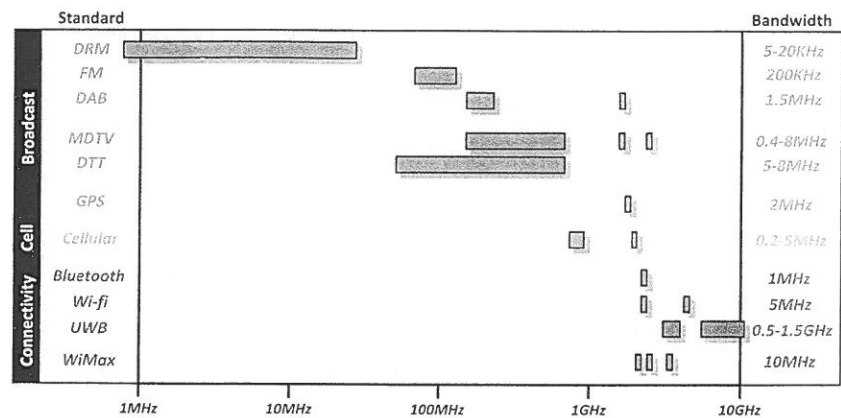

Rechargeable batteries in laptop computers by Paul Tuton

It's been my experience that these can appear to be discharged / worn out when the cells are actually fine. I've been through all the usual procedures - recalibrating and so on and seen that these have no effect. The computer constantly reports 'low battery' and most recently, an Asus laptop would run for only about 1 minute following a full charge. The battery was only about 15 months old. However, on dismantling the plastic case and removing a Heath Robinson arrangement of battery management electronics (probably the source of the problem), a quick test with a 12v headlamp bulb indicated that the cells were healthy. I reassembled them into a convenient, compact package and connected it to my Maha charger / conditioner. Sure enough, it reported that the battery was already fully charged.

I've included a digital snap of my 80m Highbridge showing the reconfigured Asus battery (Samsung cells). It provides 17v and the TX output is almost 10 watts. The battery capacity is about 3 amp hour so it lasts and lasts. Every couple of weeks, I give it boost with the Maha. If you have a laptop battery that seems to be expired after only a short life you might find that the cells are fine. They are an excellent basis for a compact, high capacity battery. I now have several and they give a few more volts than you normally get from a gel cell. Just a note of caution; handle the cells with care. They contain a lot of energy.

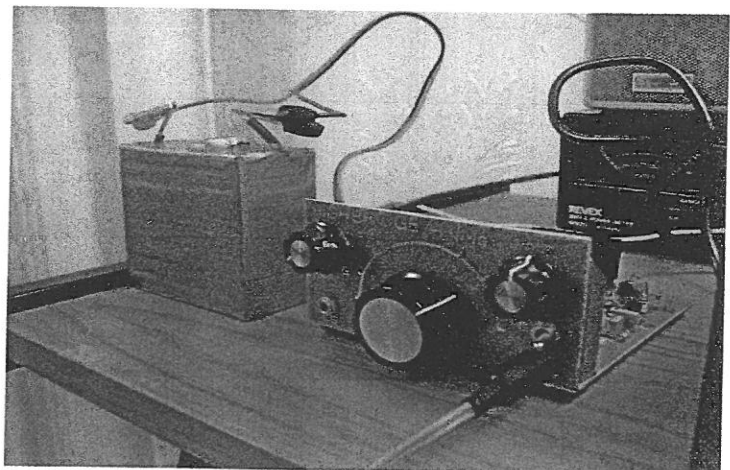

Old items wanted!

Godfrey Manning G4GLM writes saying that he operates a spares service for old transistors. He is delighted to take good old specimens when you next have a clearout! If you need an obscure old one he is also very happy to supply if he has them. He also wants useable lengths of the old style PVC 240v permanent mains installation cable that had red and black cores with or without an earth wire, (and the three core versions with red, blue and yellow). These are for restoration jobs - it is the old colours that he wants not the old sizes of wire! For those of you living in large old houses, he is also on the look out for the wood and brass electric bell indicator 'boards' that were used in the 1920/30s to tell the staff which room wanted service! If anybody can help, then I can put you in touch. Tim

QRP in the Country

Don't forget that its all going to happen here on **July 18th!** I hope that those of you in West Country already have it in your diaries! The arrangements are coming along well. There will be several threads and some of the local west country clubs are likely to have their own tables or stands. The full line up of G3GC Plank items (right) will be among the attractions!

The other attractions include:-

Construction advice clinic,
Informal home construction competition judged by our member Gerald Stancey G3MCK (who can also tell you about sundials if the sun is out!),
Somerset Range kits to operate (and even buy!), like the Tone superhet below,
Transformer throwing competition,
Bring and buy sale,
Food and drink from local sources. The Long Sutton brewery and local organic hog roast are planned!

And then you can do a farm tour led by my wife Janet. If your local Club would like a table for displays or Club items, then get them to get in touch with me. The event is open to all with free entry!

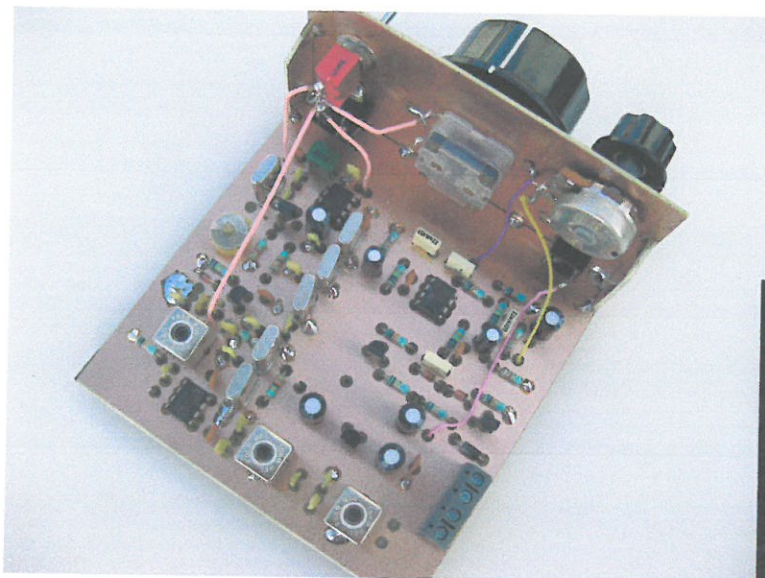

You might even see a Brent like that built by Ryan Pike! He had a good selection of 20m crystals and with a switch was able to make a compact 20m rig.



Snippets!

Very High Speed! Toshiba have recently announced the ability in their silicon foundries to offer 180 GHz RF devices using 40 nm CMOS. These devices can be integrated with other circuits on their 'system-in-package' devices. The $f(t)$ of these transistors can be 90, 140 or 180 GHz! Makes the BC182 @ below 300 MHz look a bit slow! Passive elements both capacitive and resistive can be added, as well as varactors and half turn differential or symmetrical inductors. Many of these parts have zero tempco! (What a relief - see previous page!) All you need to do is send them a net-list and Spice models etc and away you go!

Standards I came across this diagram right showing the bandwidth and frequency of various radio services recently. I must admit to being puzzled as to how many of the modern 'digital' formats are supposed to use less bandwidth than the earlier versions. (What happened to Mr Shannon's opinion?) I suppose that the digital encoding can be more efficient (so reducing the bandwidth required) but the

increase in data content brings the bandwidth numbers back up again. I am struck strongly by the increase in power consumption of many domestic receivers that is required to decode these modern formats compared to plain conventional AM or FM. This cannot be good for the environment - especially in the less developed parts of the world where simplicity, repairability and long life are more important than in so called advanced western societies.

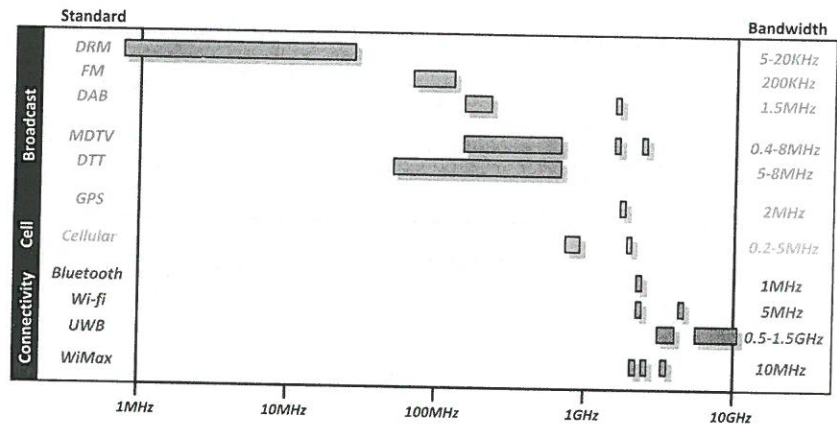

Rechargeable batteries in laptop computers by Paul Tuton

It's been my experience that these can appear to be discharged / worn out when the cells are actually fine. I've been through all the usual procedures - recalibrating and so on and seen that these have no effect. The computer constantly reports 'low battery' and most recently, an Asus laptop would run for only about 1 minute following a full charge. The battery was only about 15 months old. However, on dismantling the plastic case and removing a Heath Robinson arrangement of battery management electronics (probably the source of the problem), a quick test with a 12v headlamp bulb indicated that the cells were healthy. I reassembled them into a convenient, compact package and connected it to my Maha charger / conditioner. Sure enough, it reported that the battery was already fully charged.

I've included a digital snap of my 80m Highbridge showing the reconfigured Asus battery (Samsung cells). It provides 17v and the TX output is almost 10 watts. The battery capacity is about 3 amp hour so it lasts and lasts. Every couple of weeks, I give it boost with the Maha. If you have a laptop battery that seems to be expired after only a short life you might find that the cells are fine. They are an excellent basis for a compact, high capacity battery. I now have several and they give a few more volts than you normally get from a gel cell. Just a note of caution; handle the cells with care. They contain a lot of energy.

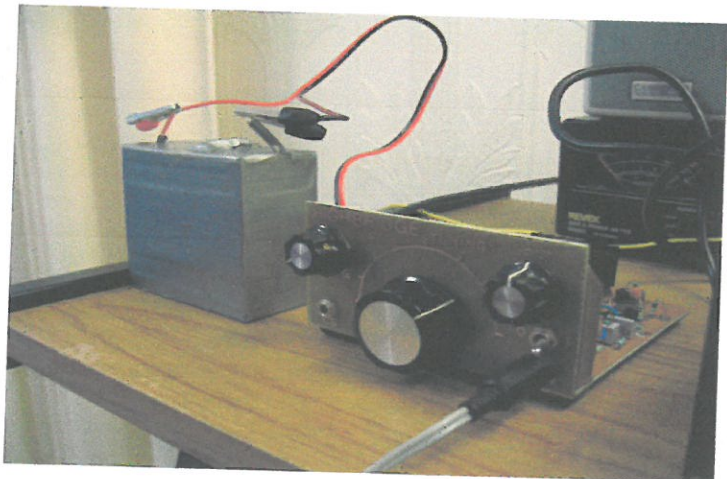

Multi-standard RF front end

requirements for the RF circuitry are principally the same, namely:

- Supporting a large frequency band of operation and wide range of channel bandwidths
- Supporting a high input signal dynamic range (low noise, high linearity)
- Co-existence with other RF functions and immunity to 'real world' interferers
- Accommodate antenna limitations i.e. size, antenna sharing, antenna isolation etc
- Low power to maximise battery life
- Enable low system cost
- Deliver a small solution size

Of course these considerations are typical to the system integration of any RF front-end, but the challenges become even more acute when co-location of multiple radios is attempted due to the aggregation of disparate requirements.

Figure 3 depicts the spectral allocation for various broadcast, cellular and connectivity standards. Even if the market requirement for an all encompassing product existed, a single front-end could not realistically enable support for the listed radio standards; the vast operational frequency range, various channel bandwidths and differing dynamic range requirements are simply beyond cost-effective implementation today.

A Multi-standard front-end example

The design of a multi-standard

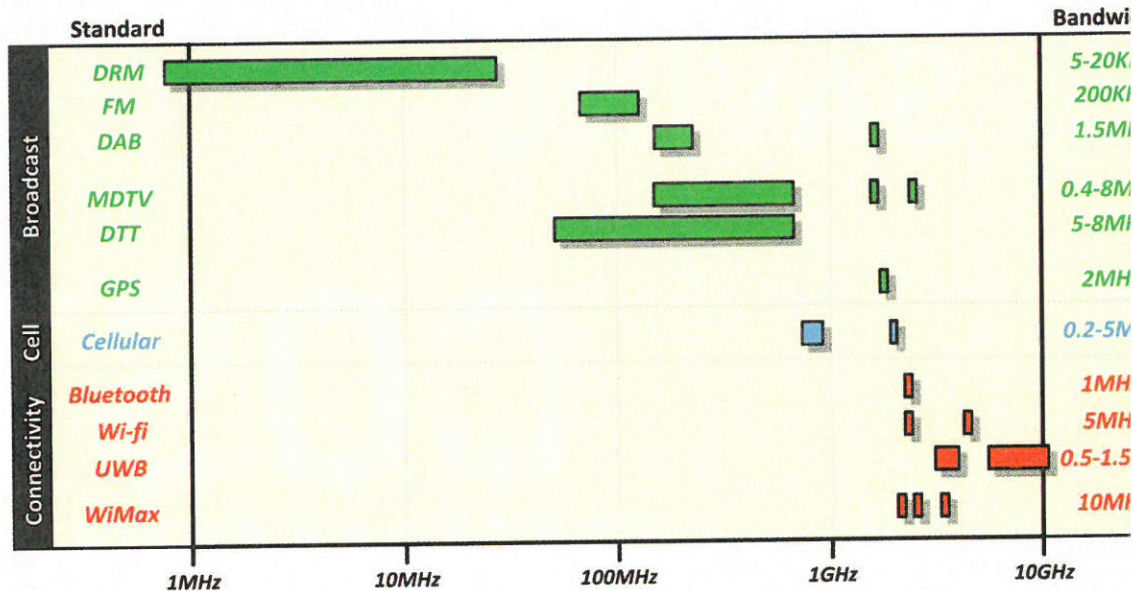

Figure 3: Spectral allocation (log scale) and channel bandwidth of various radio standards.

front-end that 'only' delivers broadcast TV and radio reception in a portable device covering FM, DAB and DVB-T (for EU market) is challenging in its own right. The receiver's synthesizer must cover one decade in frequency from 88MHz (FM) to over 800MHz (DVB-T), support frequency step sizes down to single digit kilohertz (FM), deliver low integrated phase noise to support 64 QAM modulation (DVB-T), and also feature low single-side band noise to mitigate blocking effects. Additionally, the receiver's RF input stage must support a large dynamic

range enabling reception of signal levels from as low as -105dBm (FM) to as high as 0dBm (DAB) often in the presence of interferers, whilst the baseband section must support channel bandwidths from 200kHz (FM) to 8MHz (DVB-T).

One method to address these distinct requirements would be to design multiple RF chains interfacing into multiple corresponding baseband circuits. However, such an approach would result in a die size so large as to be commercially uncompetitive if only one or two application standards were to be supported. A better approach is to employ a reconfigurable receiver architecture.

Robust performance in the presence of unwanted interferers is vital to ensuring a good user experience in the 'real world'. In the case of this broadcast receiver example, typical sources of on-channel interference include high power FM signals, whose second harmonics may fall onto the wanted DAB signal, or harmonics of DAB signals falling onto the wanted DVB-T channel.

Additionally, harmonic mixing products of the wanted signal and oscillator may also fall in-band. Other interference scenarios which result in blocking of the wanted signal include the presence of strong adjacent channels, or reciprocal mixing of wideband interfering sig-

nals due to inadequate phase noise. Careful choice of down-conversion architecture (heterodyne versus mododyne), use of harmonic rejection, and on-chip filtering help to alleviate these problems.

As Figure 2 illustrated, antenna integration must be considered in any multi-standard system. In the case of broadcast reception, multiplexing, tri-plexing and even quadruplexing techniques can be used to reduce the physical number of antennas that must be integrated on a CE device. However, wideband antenna frequency response and multiplexing insertion loss must also be considered.

There are also significant performance and size trade-offs between optimization of signal processing between the RF front-end and the initial demodulator. Analog filtering is a good example of this point: an RF front-end provides too much analogue channel selectivity if die size is negatively impacted, and conversely if insufficient analogue channel selectivity is delivered, the demodulator's analogue-to-digital conversion faces unreasonable dynamic range requirements. Such carefully considered system trade-offs can deliver significant technical and commercial benefits.

Chet Babla is director of marketing at Mirics Semiconductor

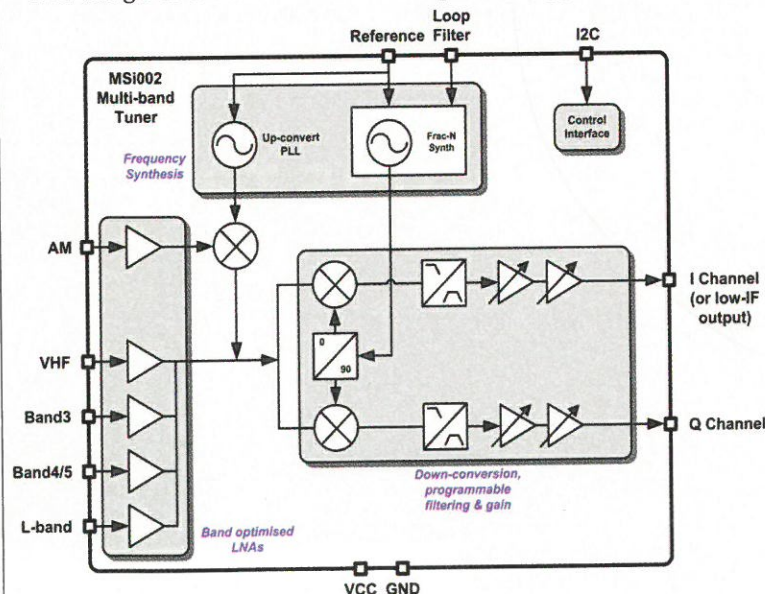

The design of a multi-standard receiver from Mirics.