

Hot Iron

Winter 2007
Issue 58

Contents

Boo!

Amplitude Modulation

Ideas for CW filters

Smart Brendons!

Tri-colour LED meter

G0UTF's ABLO rig

Harmonic VFO ideas!

Improving an HF
station

Snippets!

Somerset Supper

Editorial

Here is something slightly more inspiring and tidy than my bench! It's the operating position of Chris GU3TUX who many will know from his former life selling keys and other radio related bits and pieces. Chris moved to Alderney a few years back and now has a bit more time for using his gear. I note a couple of items that should be easily recognised by readers! The boxed TCVR on the middle shelf is a Highbridge in disguise; currently undergoing some modifications for better filtering etc. Chris uses these items with a long W3EDP antenna. Keep the pics coming please - much more interesting! Tim G3PCJ



The Walford Electronics web-site is also at
www.walfordelectronics.co.uk

Kit Developments

The **Knapp** is now available! It's a single band regen TRF on a small 50 x 80 mm single sided PCB! A few **Brendon** phone DSB TCVRs are now operating too; Steve Hartley (late of Radcom fame) is going to use them as the basis of a one day building course for novice constructors in Bath during January 2008. (If you want to participate I can put you in touch.) I hope some of those rigs will be exhibited at next years Somerset Supper - see later. I have now at long last etched a **Minster** but am awaiting its return from drilling. Assuming the basic rig works as intended on any single band 20 to 80m, then I shall start on the 'extras' package which will give it any two more bands and several extras. I have also lately realised that retiring the Kilve has left a gap in the range at the low end - I hope to plug this with the **Willet** - a three band (20/40/80m) simple DC RX. I have laid this out with a LM380-8 audio output stage in the flat 80 x 100 mm format. The target price is about £25 - I awaiting the return of the first PCB from drilling and must then check that it works well enough to be a viable receiver. I have also been doing several technically interesting experiments (see later) that might be incorporated into rigs in the future.

As Christmas is not all that far off, so I wish you all a very Merry Christmas, Tim Walford G3PCJ

Hot Iron is a quarterly subscription newsletter for members of the Construction Club. Membership costs £7 per year with the first issue for each year appearing in September. Those people joining later in the year will be sent the earlier issues for that year. Membership is open to all and articles or questions or comments or notes about any aspect of electronics—principally on amateur radio related topics— is very welcome. Notes on member's experience building their own gear, from kits or otherwise is most interesting to other constructors. To keep it interesting, your thoughts and ideas are required please! For membership, I only need your name and address and subscription. Send it or any other suggestions to Tim Walford, Walford Electronics, Upton Bridge Farm, Long Sutton, Langport, Somerset TA10 9NJ © G3PCJ

Boo! By Richard Booth G0TTL

This little project came about during the development of a superhet transceiver that I am working on. The plan is to design it using a minimum of components to keep cost and complexity down. I must be one of a few people who makes his own equipment and has never used an LM386 audio amplifier! So I wanted to try one out and by using this particular device which has a voltage gain of up to 200, the theory is that you can do away with an audio preamplifier stage; this fits my design plan perfectly. That fact in mind, I also wanted to try out the possibilities of using the internal oscillator of the SA602 mixer as a Colpitts style VFO with a single winding toroid (no taps) and variable capacitor as frequency control. Again this approach would save an extra transistor oscillator stage in my eventual superhet project. Rather than muck about with breadboards testing ideas I prefer to build something more substantial, especially when testing VFO circuits. This gave me an excuse to put together a little direct conversion receiver for 80M.

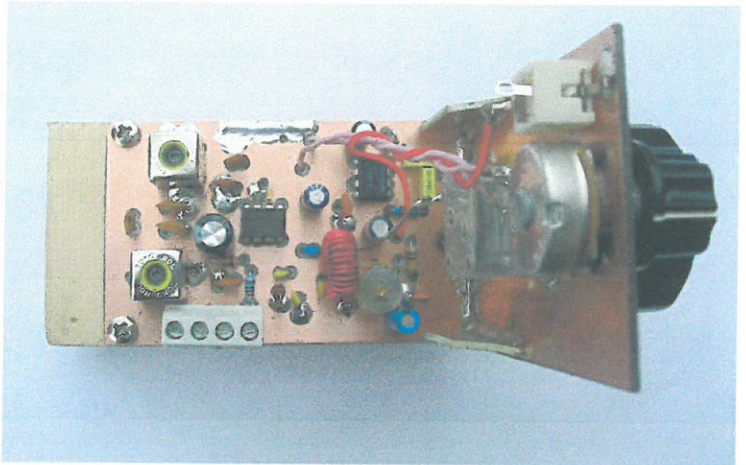

Construction is straightforward, the layout not being particularly critical although care needs to be taken around the audio stage due to the high single stage gain. You can build it on my 80x50 mm double sided PCB or ugly bug style. Use ceramic plate capacitors for the RF input band pass filter which uses a pair of TOKO 3334. The Colpitts VFO around pins 6 & 7 of the SA602 uses two types of capacitor. The 1nF types need to be N150 ceramic plate (orange tips) and the 330pF and 150pF are NPO types. This helps to improve temperature and frequency stability so worth fitting the correct variety. The toroid "L" is made up from 31 turns of 24 SWG, close wound on a red T50-2 core. There is just enough room for this winding in a single layer. Make the turns tight. My prototype covered the whole of 80M using the 75pf section of a Polyvaricon variable capacitor - use the 65pf trimmer in parallel to adjust the operating frequency range. The audio stage uses a LM386N-4, I chose the "4" version as this is the higher operating voltage type, which will stand up to 18V. All electrolytic capacitors are rated at 35V, the 100nF components are miniature polyester. The rest of the other capacitors are ceramic disc. You can either use a 9V battery or your 13.8V supply. Do check the polarity before switching on.

When complete, set the operating frequency of the VFO using a counter, you can temporarily hook it up via a divide by ten probe to pin 7 of the SA602. Otherwise use another receiver to listen for the VFO in the usual manner and adjust. If you use the suggested values it should be very close to the 80M band and need little adjustment. Now connect up your antenna, tune to mid band and find a signal. Then just peak up the cores of the two TOKO inductors for best signal to noise ratio.

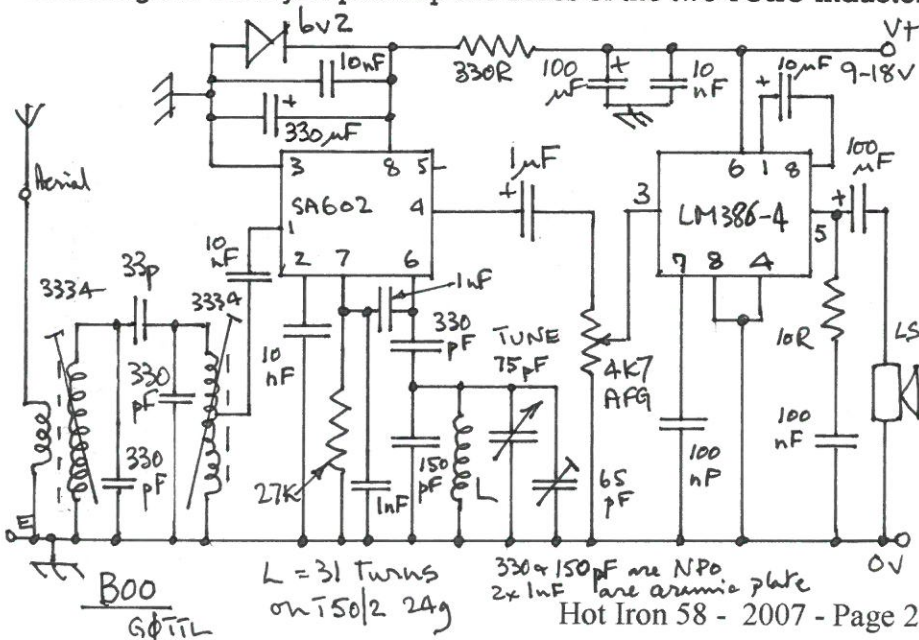

After completing this receiver I realised the original concept of strapping a 602 and 386 together had already been developed by a certain George Dobbs, G3RJV in the "Sudden". Some may say great minds think alike! I will now get on with making a superhet version of this, the next job is to build and test a home made 9MHz SSB crystal ladder filter. If you want a PCB, I can supply them; give me a call - Tel 01302 858468. Happy Christmas, Richard G0TTL

Amplitude Modulation techniques

There is quite a lot of activity and interest in Amplitude Modulation, with regular nets on 160m and, I am told, also on 40m. Prior to very narrow IF filters becoming cheap, making single sideband economically feasible, AM was THE mode of phone operation.

AM Receivers TRF receivers (often with regeneration) were common before superhets - the TRFs had amplitude detectors after the RF amplifiers to detect the peaks of the RF envelope, which were then passed to following audio amplifiers. While this was originally done with valves, it is now much easier with FETs and bi-polar transistors as in the Knapp regenerative TRF RX. This uses an infinite impedance FET detector to rectify or detect the peaks of the RF signal. A plain diode could be used instead but this will load down the RF tuned circuit and reduce its Q and or the sensitivity, whereas the infinite impedance detector works like a perfect diode that does not load the driving tuned circuit! Unfortunately it is not possible to make the product detector of a normal direct conversion receiver work as an amplitude detector while still retaining its selectivity - AM really requires a different approach. One of the easiest ways is to use an old AM broadcast band car radio which can often be picked up at rallies for a £1 or so, working in conjunction with a simple converter. The converter just shifts the received signals down to a convenient section of the medium (or long wave) band with the car radio acting as a tuneable IF, detector and audio output. This scheme is easily done with a SA602 mixer oscillator chip as shown right. You need a crystal whose frequency is about 750 KHz to 1 MHz either above or below the band you wish to listen to - the exact figure is not important as you just adjust the car radio's tuning to suit! 5.5 MHz suits 40m and 2.5 MHz does 160m.

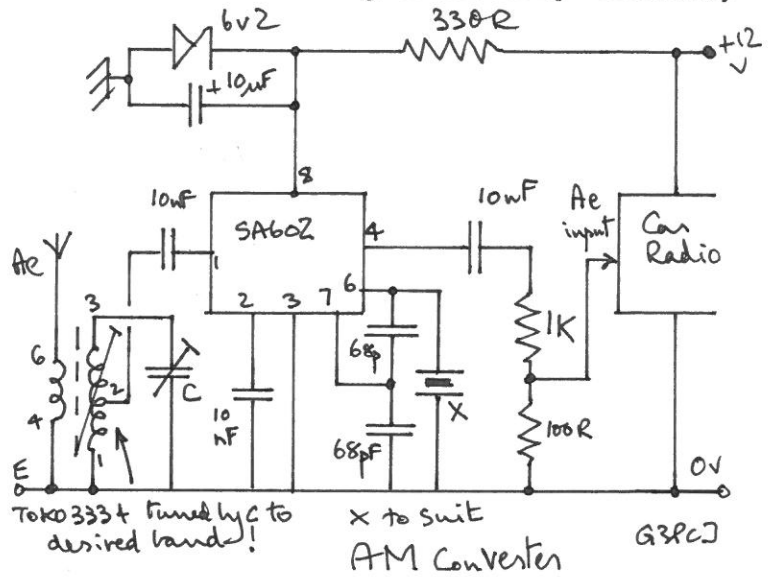

AM Transmitters Traditionally this was done by using a powerful audio amplifier to 'modulate' the HT supply of the output stage of a CW transmitter. This approach does have the advantage that an existing CW simple transmitter can be used because it does not have to be linear through all the RF stages as in an SSB transmitter. It is certainly possible to do this with transistorised equipment but the major drawback is that it often needs an expensive special audio transformer. Another approach is to modulate at rather lower level and use a linear amplifier to obtain the desired output level. The RF amplifier operates continuously at the desired carrier power, going up to peaks of four times that on speech peaks and down to zero on the troughs. This means that a 10W peak RF amp, like my linear kit (on 13.8 supplies), can run a 2.5W carrier on AM. Its gain is about 8 dB so it would need around 300 mW carrier input going up to 1.2 W on peaks. This suggests that a LM380 audio amp chip can directly modulate a lower power RF amp as a driver to the Linear. This is done by using the audio amp's normal DC output of half the supply voltage to feed the RF amp final stage without any coupling capacitor. The **Kilton**, normally 1.5W of CW on 13.8v, is ideal if its output stage is powered at 6 volts by an LM380 from my **Audio Amp** kit! The oscillator section of the Kilton is run on 13.8 volts as normal. This is an easy alteration to make! What's more, there are 2 MHz ceramic resonators that can be directly used on 160m in the Kilton provided the output low pass filters are also altered for 160m! Worth a try! Tim G3PCJ

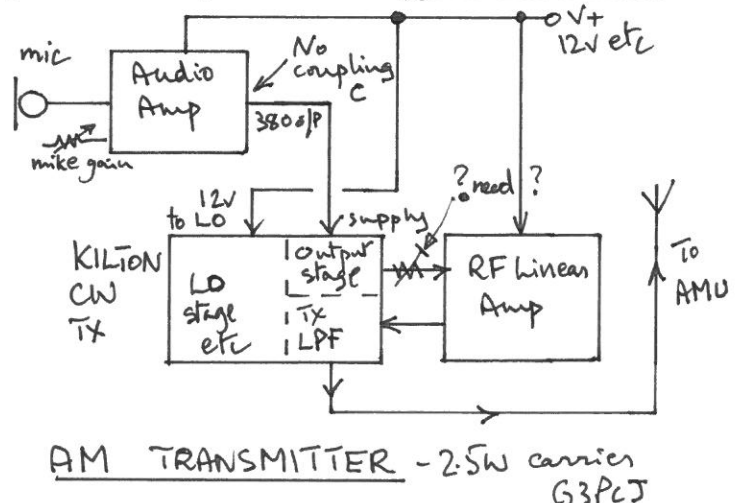

Ideas for CW filters!

While considering what filters to put into the Minster for CW, I went wild and contemplated variable bandwidth, variable centre frequency, choice of peak or null or direct etc!! Variable bandwidth with fixed centre frequency is relatively easy and I have had a kit for this for some years using adjustable coupling between two filters, but a 'simple' variable frequency design had eluded me - I particularly wanted to avoid having to use two gang pots. For CW it is also important that although one might want a narrow bandwidth implying high Q, the filter should not ring. After playing with most of the common op-amp filter networks, including the 'state variable' filter that uses two integrators and an inverter, I hit on the idea of using two *all pass* phase shifters to provide the 180 degree shift required for near oscillation instead of the state variable's integrators. The *all pass* filter has unity gain but just alters the phase delay (or advance) as the signal passes through it, hence it would be possible to change the delay, and thus frequency, without altering the overall gain or Q of the whole circuit. The box right shows the scheme. The simple arrangement shown is a peaking bandpass filter, where, as the variable R element is decreased, it gets nearer to oscillation with a decreasing bandwidth or higher Q. In this simple scheme the overall gain does alter with Q but there are ways round that if bandwidth has to be a front panel control!

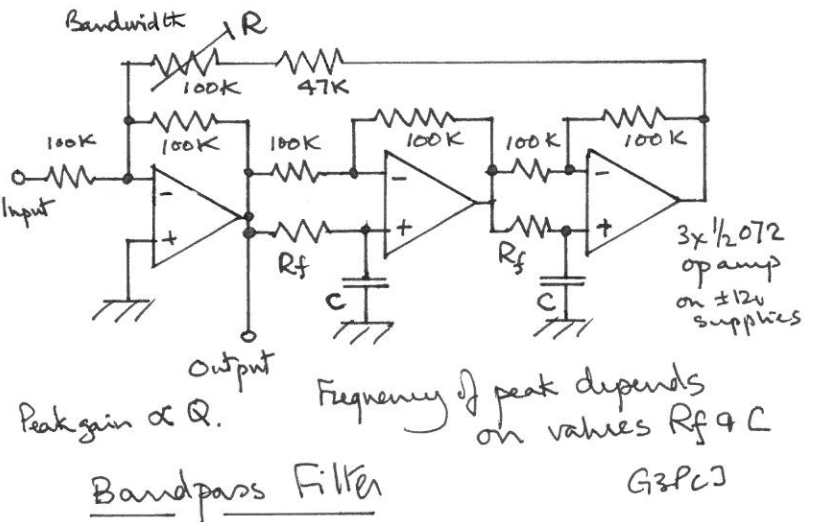

It then dawned on me that the two phase shift stages need not have the same delay as long as their combined shift comes to 180 degrees. This means that by varying just one of them, with a single pot, one could alter the centre frequency! This worked excellently and I even managed to devise a version (with an extra op-amp) that had constant gain irrespective of the Q! By adding yet another op-amp to subtract the filter output from the original input signal one can turn it into a notch filter too! With a centre off toggle one could have straight through, notch or peak outputs! In the basic version there was some evidence of very HF instability so I added a couple of CR's to reduce the HF gain. However by this time it was looking like at least 5 op-amps and getting far too complicated, but it was an interesting exercise and might encourage readers to explore the ideas! The circuit below uses ground referenced biasing for + and - 12v supplies; a single supply design will need mid-supply biasing. I still have to decide exactly what I will put for CW in the Minster! Tim

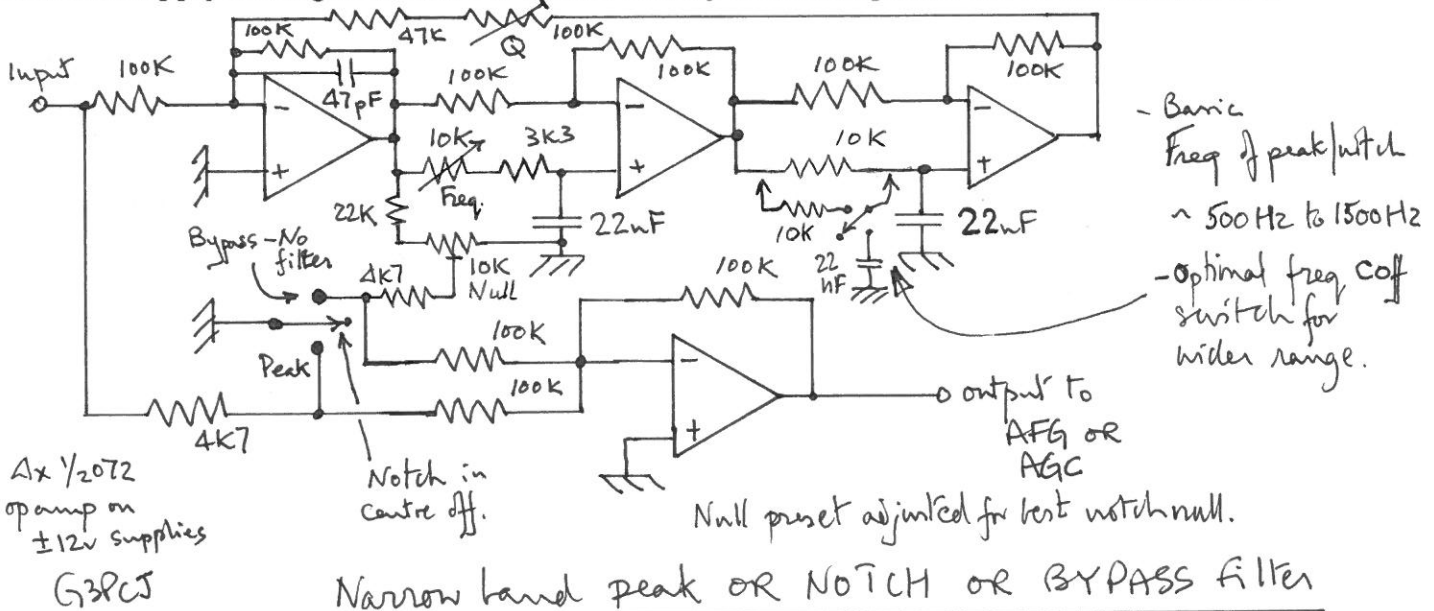

Smart Brendons!

Here are a pair of very smart Brendons built by Paul GOVHT and Richard GOTTL. Paul is working on adding a linear RF amp that was salvaged from an earlier project. Richard has added a 3 digit counter to his (right).

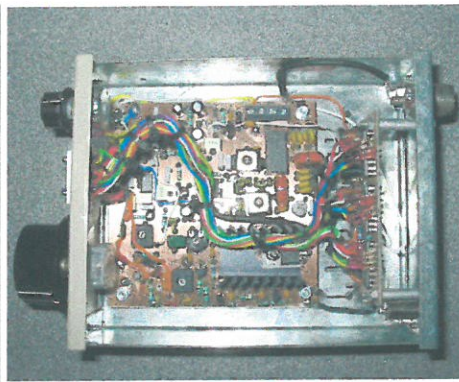

Tri-colour LED meter

After floating this idea last time with an untried circuit, I did eventually get round to seeing if it worked - it did but not quite as well as it could! The circuit right is much better, with the colour changing gradually from nothing (up to 2 volts) rising to full green at about 5 volts, to orange at 8 volts, then progressively brighter red for over 8 volts. The loading on the driving circuit is about 80K min. It is a viable low cost and low space alternative to expensive moving coil meters - but see the back page! G3PCJ

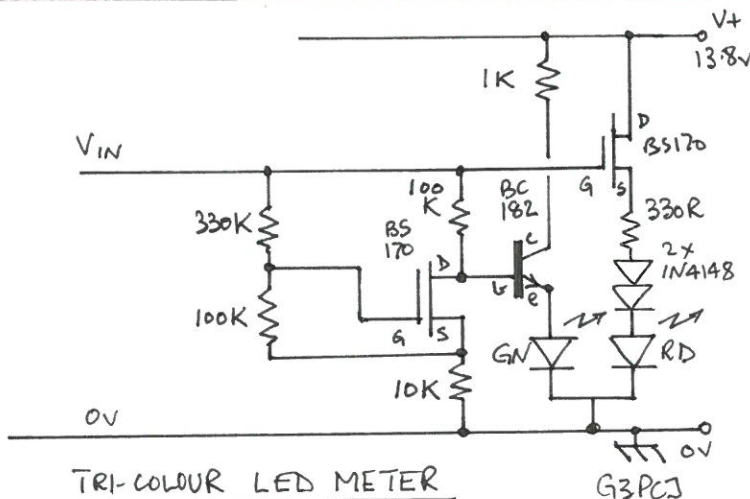

The ABLO

David Proctor G0UTF has been using an ABLO to drive his CW TX which I think had its origins from another kit supplier (Dave Howes). It should eventually do all the HF bands that the ABLO can do, but so far he reports good results on 40m. It also has a LED digital frequency readout. The TX, with its low pass filters, is mounted in the bottom section below the ABLO. As an aside he commented on the excellent filtering qualities of his Howes CW filter which had made several contacts to Europe possible when the lack of a filter would have prevented them. Dave H's design used double twin T bandpass filters for CW after sharp cut-off SSB filters.

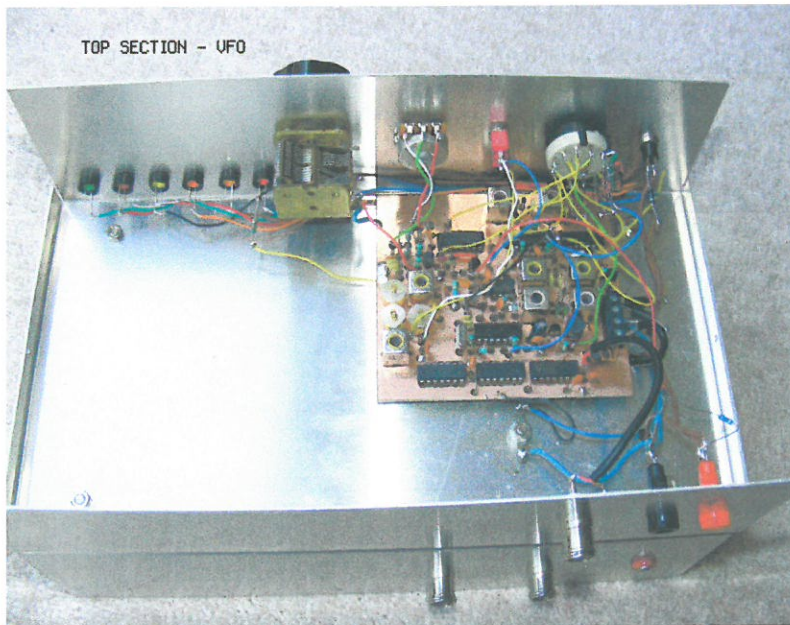

Improving an HF Radio Station - by Dave Buddery G3OEP

(I have shortened this from some longer notes that Dave kindly sent me - G3PCJ)

The transceiver Does a rig that is only 15 years old really need realignment? Probably not unless it has suffered physically, or has been used /P. Regularly used rigs seldom need tuning re-alignment - they might need checks of bias voltages, sticking relays & higher value capacitors.

Power leads Are they heavy enough to avoid a significant voltage drop (less than few %) under full output? Are they and the RF leads, aerial wires etc in good condition? Good RF insulators can be made from plastic chain link fencing!

QRP Operation Need to make certain that every milliWatt of RF gets radiated hence put max effort into obtaining a good aerial and earth system, with low loss feeders and an efficient AMU.

Earth system Remember its half the aerial! Is it in good condition? Is the local soil a good conductor, and is there enough rod etc to make a good ground contact? Consider using a counterpoise. Note that an 'artificial earth' is often a short length of wire tuned or loaded by its own AMU to make it look like a quarter wave.

Aerial poles Difficult! Use heavy duty 16ft long bamboo if available, fibreglass 'rods' or lash shorter ones together with an overlap of about 18 inches. Lash to a strong supporting post sunk in the ground, and guy it if it bends! Use three equi-spaced guy wires from about two thirds its full height if the pole is supporting the middle of the aerial and NOT pulled sideways by it. If it is on the end of aerial, then one guy wire must be directly opposite the aerial wire and right at the top.

Aerial wires The thinner and lighter, with less windage, the better but thin aerials have narrow bandwidth. Steel wire is OK but hard drawn (split BT 'drop-wire' figure of 8 pair) or plain copper wire is better. Generally get as high as possible and ideally half a wavelength long (total) on your lowest band; does not matter if the ends hang down but make sure not touchable - to avoid shocks!

Aerial feeders Open wire ladder line to a versatile balanced output AMU is probably the least lossy. Even when the line impedance (which is high - often 300 to 600 R) is NOT matched to the antenna's feed point impedance, the losses will be negligible at HF. Can be easily made with two copper wires using spacers about 4 inches long made of plastic strip material, about 3 ft apart.

Aerial halyards Using a ring or pulley attached to top of pole/tree/house etc, through which the halyard is threaded will enable you to raise/lower the aerial without use of ladder etc. One end of halyard attached to aerial insulator, other end over pulley down to ground level and is attached to a cleat to secure it, or a suitably heavy suspended weight to allow some give. Some prefer the halyard to be continuous, connected end to end, so that it cannot be lost up the tree!

Baluns Theory suggests these should always be fitted at the junction of aerial and feeder, to make sure the inherent balance of the aerial (assuming it has symmetrical length arms) is maintained. Practical experience suggests their main value is helping to reduce TVI.

RF Ammeters Used to be available from Air Ministry! Tend to be a bit fragile. Low voltage (hence low resistance) filament bulbs in series with aerial conductor are another cheap option. Better to thread aerial lead through centre of a small ferrite toroid RF transformer, made from a few turns on toroid feeding a sensitive RF voltmeter. Use a small diode (ideally germanium or Schotky), 100 nF smoothing cap and a sensitive meter - moving coil 50 or 100 micro-amps FSD.

Versatile aerial system This design is favoured by many for all band use:-

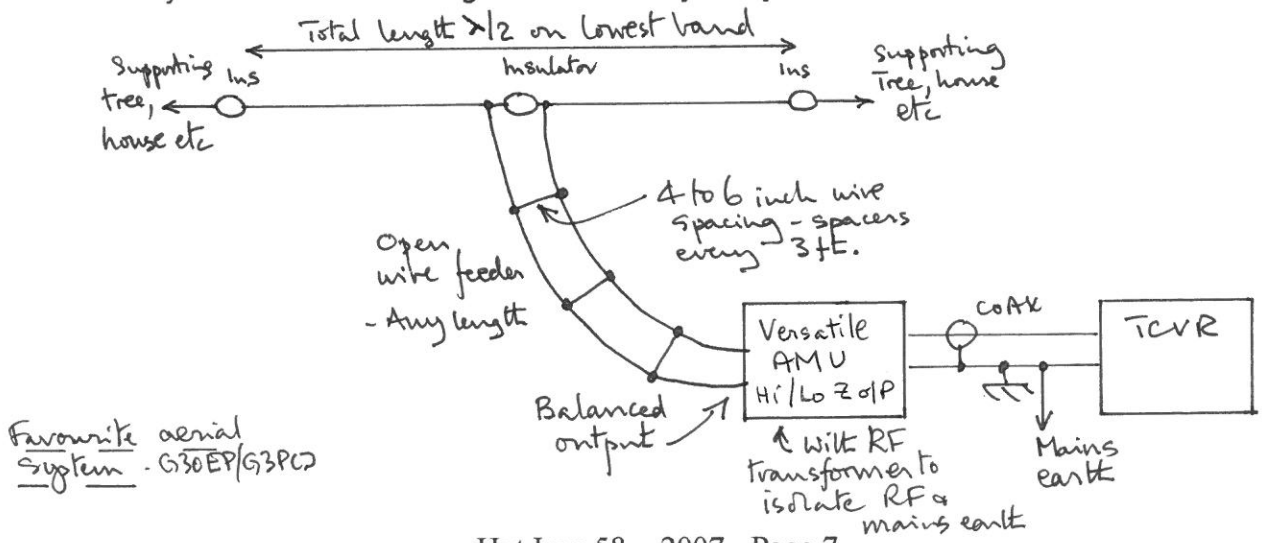

Snippets!

Moving coil meters I have some excellent brand new 50 uAmp meters with rectangular 2.25 x 2.75 inch faces. Because I got these cheap I can offer them at three for £10 plus £3 P and P. G3PCJ

Aerials and SWR There is an excellent summary of what is important for aerials, feeders, AMUs and the like in the December 2007 Radcom as part of Pat Hawkers G3VA's Technical Topics article. His regular column alone makes it worth being a member of the RSGB! Pat has been writing this column for decades and has an excellent gift for bringing forward new developments while setting them in the context of what was found out by the early radio pioneers - he does a grand job and will be a hard act to follow when he eventually puts down his pen. If you read this, please Pat, don't do that for a long time yet! One should support the National society anyway since non-members have no means of influencing Gov policy etc; the RSGB generally does a generally good job for us even if some aspects do cause annoyance. Its no good moaning if the message cannot be delivered!

MOEZP's Sutton After that slightly embarrassing photo of his rig under threat from me with an angle grinder, I can now report that it is working as intended! David's rig has many additions of which the most important was a Linear RF amp. When the linear was connected after the normal output stage but before the TX output low pass filters as advised, the rig appeared to be unstable with very unpredictable readings on most bands. The trouble was traced to the LO input to the transmitter's balanced modulator - this being fed from a medium impedance source in the RX's Local Oscillator chain. Examination with the scope showed that this waveform was triangular rather than sinusoidal and hence full of harmonics. These harmonics were upsetting the TX and following Linear. Why was the LO drive triangular? This did not take long to explain and cure. The signal was derived from the RX's LO SA602 mixer chip LO input buffer transistor; this runs at a bias of a fraction of a milli-amp (even with an extra 10K external emitter resistor), consequently it is able to pull up the load capacitance rather more quickly than the emitter resistor can pull it down! Hence the triangular waveform. The cure had to be to reduced the capacitive load on this buffer stage - it turned out that David had wired it with miniature coax which represented a capacitive load of several tens of pF! The cure was to change this coax to a short single core plain wire run close to the PCB - simple! Waveform became sinusoidal, no harmonics and the rig was stable!

In general it is often better to use short direct wires between signal points in RF circuits if the distances are only small fractions of a wavelength, particularly if the source is not low impedance. The capacitance of the wire will be much less; while running it close against the ground plane(s), so as to minimise the area enclosed by the wire and the current return path, will reduce the inductance so that there is less reactance overall on the driving device.

Knapp Here is a photo of what this little Regen TRF Rx looks like - built by GOTTL

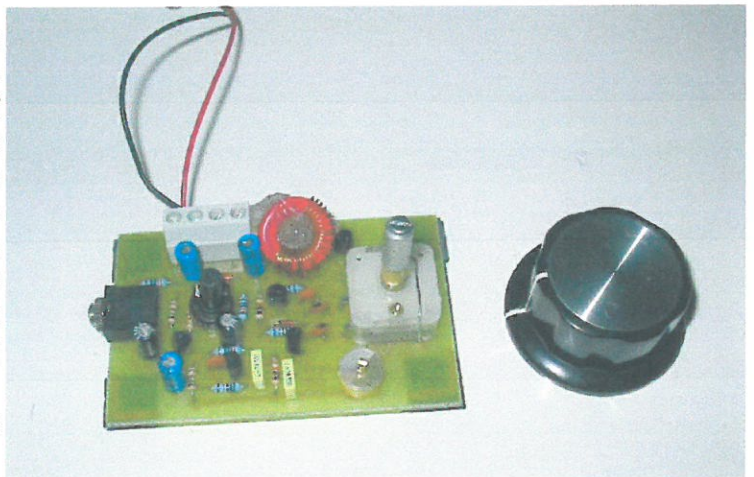

The Somerset Supper and Yeovil QRP Convention

The fourth supper will be held on Saturday April 26th 2008 at the Antelope Hotel, Sherborne (as last year) area for locals and those staying overnight. This is the evening before the Yeovil QRP Convention. As before there will be a small display of items from each diner's home built radio equipment! This will qualify you for a **free** place at the supper table! The display will be judged by **Steve Niewiadomski**, who contributes interesting construction articles to PW; he is also speaking at the Convention. Places by advance booking **only** by April 19th so please tell me if want to come. Hope to see it and you! Tim G3PCJ